

EPAC

Operation Instruction Manual

**VERSION: V3.XMP NON-INSTRUSIVE WITH
DATALOGGING
(Weather Proof & Explosion Proof)**



Table of Contents

1. SAFETY INSTRUCTIONS	3
1.1 BASIC INFORMATION ON SAFETY	3
1.1.1 STANDARDS/DIRECTIVES	3
1.1.2 SAFETY INSTRUCTIONS/WARNINGS	3
1.1.3 QUALIFICATION OF STAFF	4
1.1.4 COMMISSIONING	4
1.1.5 OPERATION	4
1.1.6 PROTECTIVE MEASURES	5
1.1.7 MAINTENANCE	5
1.2 RANGE OF APPLICATION	5
1.3 REFERENCES AND SYMBOLS	6
2. INTRODUCTION	7
2.1 LCD DISPLAY & LED INDICATION	7
2.2 INBUILT FRONT PANEL OPTION SELECTION	7
2.3 INTERFACES	7
2.4 EMERGENCY STOP - ESD	7
2.5 EVENT STORAGE & DATALOGGING OPTION	8
2.6 PARTIAL VALVE STROKE TEST (PVST) OPTION	8
2.7 INHIBIT OPTION	9
2.8 REMOTE SELECTOR SWITCH	9
2.9 LOCAL CONTROL STATION (LCS) PRIORITY	9
2.10 REMOTE LOCAL STOP	9
2.11 TIMER MODE	9
2.12 PROGRAMMABLE RELAYS	10
2.13 REAL TIME CLOCK (RTC)	10
2.14 POWER SUPPLY	11
2.15 SURGE PROTECTION AND LIGHTENING ARRESTER	11
3. FRONT PANEL DETAILS	12
3.1 SELECTOR SWITCH	12
3.2 PUSH BUTTON SWITCHES	12
3.3 LCD SCREEN & LEDS	12
4. MODES OF OPERATION	14
4.1 PROGRAM MODE	14
4.1.1 EDIT/VIEW OPTION OF PROGRAM MODE	14
4.2 CALIBRATION MODE	23
4.2.1 LIMIT CALIBRATION	25
4.2.2 DAC CALIBRATION	26
4.2.3 4-20MA CALIBRATION	28
4.2.4 CHANGE TORQUE VALUE	29
4.2.5 PRESET TORQUE	30
4.3 DIAGNOSTIC MODE	35
5. TOPOLOGY CONNECTION	37
6. REGISTER DETAILS FOR MODBUS COMMUNICATION	40
7. TROUBLESHOOTING	43
8. EPAC NAMEPLATE	47
9. DISPOSAL AND RECYCLING	49
10. SERVICE	49

1. SAFETY INSTRUCTIONS

1.1 Basic information on safety

1.1.1 Standards/Directives

AUMA INDIA products are designed and manufactured in compliance with recognized standards and directives. The list of certifications & agency of certification for Auma India products are as given below..

	Model	Certification	Agency
1.0	SA Ex /SAREx3 to SA Ex /SAR Ex100 SAC Ex /SARCEx3 to SAC Ex /SARCEx100	Marks license number CM/L - 6169979	Bureau of Indian Standards
2.0	SA Ex /SAREx3 to SA Ex /SAR Ex100 SAC Ex /SARCEx3 to SAC Ex /SARCEx100	The actuator are approved for use in Zone 1 of Gas Group IIB hazardous area & for the safety protection Ex d IIB T4 as per IS/IEC60079-1:2007	CCOE/PESO, Nagpur
3.0	SA Ex /SAREx3 to SA Ex /SAR Ex100 SAC Ex /SARCEx3 to SAC Ex /SARCEx100	The actuator are approved for use in Zone 1 of Gas Group IIB hazardous area & for the safety protection Ex d IIB T4 as per IS/IEC60079-1:2007	CIMFR, Dhanbad
4.0	SA Ex /SAREx3 to SA Ex /SAR Ex100 SAC Ex /SARCEx3 to SAC Ex /SARCEx1002	Temperature rise classification of flameproof actuators (T4 certificates)	CIMFR, Dhanbad
5.0	EPAC modules	EFT TESTS Surge tests Susceptibility tests	ETDC
6.0	EPAC modules	EMI & EMC CERTIFICATION	Sameer Labs
7.0	Design, Production , after sales and services Actuators & Gearboxes at Auma India Pvt Ltd.	ISO:9001- 2015	TUV Nord
8.0	Environmental management system at Auma India Pvt Ltd.	ISO14001:2015	TUV Nord

All legal requirements, directives, guidelines, national regulations and recommendations with respect to assembly, electrical connection, commissioning and operation are to be met by the end user or the contractor at the place of installation. Customer has to follow specified standards for electrical installations in explosion proof at& other hazardous areas. Modbus RTU application related configuration guidelines are to be followed.

1.1.2 Safety Instructions/Warnings

All personnel working with this device must be well-versed with the safety and warning instructions in this manual and observe the instructions given. In order to avoid personal injury or property damage, the safety instructions and warning signs must be observed carefully. Kindly follow Common Electrical and Electronic related safety instructions according to industrial standards. The main mechanical safety instructions are fixed on the actuators as

shown below.

Safety Instructions on Actuators:



Weather Proof and FlameProof/ExProof Safety instructions



FlameProof/ExProof Safety instructions

1.1.3 Qualification of staff

Assembly, electrical connection, commissioning, operation, and maintenance must be carried out exclusively by suitably qualified personnel having been authorized by the end user or contractor of the plant only. Prior to working on this product, the staff must have thoroughly read and understood these instructions and, furthermore, know and observe officially recognized rules regarding occupational health and safety.

Work performed in potentially explosive atmospheres is subject to special regulations which have to be observed. The end user or contractor of the plant is responsible for respect and control of these regulations, standards, and laws.

1.1.4 Commissioning

Prior to commissioning, it is important to check that all settings meet the requirements of the application. Incorrect settings might present a danger to the application, e.g. cause damage to the valve or the installation. The manufacturer will not be held liable for any consequential damage. Such risk lies entirely with the user.

1.1.5 Operation

Prerequisites for safe and smooth operation:

- Correct transport, proper storage, mounting and installation, as well as careful

commissioning.

- Only operate the device if it is in perfect condition while observing these instructions.
- Immediately report any faults and damage and allow for corrective measures.
- Observe recognized rules for occupational health and safety.
- Observe the national regulations.

1.1.6 **Protective measures**

The end user or the contractor is responsible for implementing required protective measures on site, such as enclosures, barriers, or personal protective equipment for the staff.

1.1.7 **Maintenance**

Auma India multi-turn actuators require very little maintenance but they need to be tested regularly for its correct functioning. After commissioning, check actuator for damage to paint finish. Do a thorough touch-up to prevent corrosion. Correct commissioning is a prerequisite for reliable service. Seals made of elastomers are subject to aging and must therefore regularly be checked and, if necessary, exchanged. It is also very important that the O-rings at the covers are placed correctly and cable glands fastened firmly to prevent ingress of dust or water.

We recommend additionally:

- If operated seldom, perform a test run about every 6 months. This ensures that the actuator is always ready to operate. The version of actuators discussed in this manual have an option for *Partial Valve Stroke Test (PVST)* to check if the actuator is healthy.
 - Approximately six months after commissioning and then every year check bolts between part-turn actuator and valve for tightness. If required, tighten applying appropriate torques.
 - The gear housing is filled with lubricant in the factory. This filling lasts for several years of service.
 - Corrosions of paint damage parts must be prevented through touch up.
- Any device modification requires the consent of the manufacturer.

1.2 **Range of application**

Auma India actuator controls are exclusively designed for the operation of Auma India actuators. Other applications require explicit (written) confirmation by the manufacturer. The following applications are not permitted.



- Motor control
- Pump control

No liability can be assumed for inappropriate or unintended use.

Observance of these operation instructions is considered as part of the device's designated use.

1.3 References and symbols

The following references and symbols are used to provide information of the basic actuator commands to the customer. They are:

-  Symbol for CLOSED (valve closed)
-  Symbol for OPEN (valve open)
-  Symbol for STOP (valve stop)

2. INTRODUCTION

AUMA INDIA has developed a new range of electric actuators with intelligent integral starter using microcontrollers for weather proof and explosion proof applications that has the ability to store events and other upgraded features. As a microcontroller is used, the actuators support both ON-OFF and Regulating Duty Control. The actuator can also be run in Inching or Non-Inching mode. The important features of these electric actuators are as follows:

2.1 LCD DISPLAY & LED INDICATION

Options can be selected by using the selector switches, push buttons based on the instructions displayed on the LCD screen. Information on faults/statuses can be obtained from the 4 LEDs next to the LCD. The 4 LEDs are configurable as per user requirement before-hand. LCD screen facilitates easier understanding of status, operation and parameter setting details. More information regarding this is described in section 3.

2.2 INBUILT FRONT PANEL OPTION SELECTION

Different features/options of the actuator can be configured using software. This is done using the selector switches, push buttons based on the instructions displayed on the LCD screen that is present on the front panel. More information regarding this is described in section 3.

2.3 INTERFACES

This actuator is capable of supporting different types of interfaces like Remote – 4 Wire, Remote -2 Wire Make/Break, 4-20 mA Regulating Duty & MODBUS-RTU.

2.4 EMERGENCY STOP - ESD

ESD feature is default configured to run in Close direction on enabling ESD. One needs to enable ESD and set its behavior in Program Mode for it to function. An ESD via MODBUS option is also available that needs to be enabled in Program Mode. ESD Operation can be configured for OPEN/CLOSE/STAY. One can choose to set ESD on TOLR Ignore, TH Ignore, Space heater Fail Ignore, OFF Ignore. This means that ESD operation would occur irrespective of these faults. One must enable ESD on program mode and set its behavior (ESD Open/Close). An ESD NO/NC configuration is also

available that can be configured in Program mode. ESD feature now can be carried out using an external 24VDC supply also.

2.5 EVENT STORAGE & DATALOGGING OPTION

This range of actuators comes with an option to store events such as faults, statuses, number of starts (Open in Local/Remote etc. using a Bluetooth module). The events are stored in a flash memory and can be read via Bluetooth. The data logged will have a real time stamp and can be downloaded using a user-friendly application called Auma India Utility Software onto a PC/Laptop with Bluetooth connection. About 43691 events can be stored at a time using this module. AIUS is also used in assisting commissioning and diagnosing the actuators. Device Tag is customer configurable. Remote Operation of actuator through Bluetooth is also available.

The available events are as follows:

- Number of Starts (Open and close in specified duration)
- Open and close Command with Selector Switch Position
- Tripping Torque Profile (Non-Intrusive)
- Faults.
 - Loss of Phase
 - 24 V Fail
 - Thermal Switch Trip.
 - Torque Switch Trip
 - Control Supply Failure
 - TOLR
- Selector Switch Change.
- End Position
- ESD

More details of this feature is available in AIUS User Manual (Doc. No.: 4-AIUS-MANUAL-39396).

2.6 PARTIAL VALVE STROKE TEST (PVST) OPTION

This feature is used in checking correct functioning of valves which are not operated for a long period. When PVST is triggered the valve moves to particular percentage and come back to the same end position and gives PVST result. The features are:

PVST can be triggered externally through a switch or via MODBUS.

PVST command can be given through MODBUS using dedicated registers.

PVST Position can be configured in the following two ways.

From Open End

From Close End

PVST Percentage can be set to any of the three options.

5%, 10%, 15%

PVST Failure : This failure occurs when the PVST command doesn't take place after a specified time

(that is specific to actuators based on its RPM and No. of Turns). This failure is indicated by using any one of the programmable relays present in your module.

2.7 INHIBIT OPTION

Inhibit is an interlock for open close operations. Inhibit Operation can be Enabled or Disabled in Software (Program Mode). In this module, separate terminals for Inhibit Open and Inhibit Close are available. Based on this, Open/Close Commands can be inhibited.

2.8 REMOTE SELECTOR SWITCH

This option allows the user to create a selector switch for the actuator in Remote mode. It is mainly used to lock/unlock the Local operation of the actuator using push buttons through a Remote command. This serves as a software lock.

2.9 LOCAL CONTROL STATION (LCS) PRIORITY

When this feature is enabled, the user can control the actuator in remote 4 –wire mode of operation even when in 4-20mA or MODBUS mode of Operation.

2.10 REMOTE LOCAL STOP

This option is also software configurable and can be enabled in Program Mode. The actuator should stop running in Remote Mode when STOP key is pressed in the Actuator Front Panel. No commands should be accepted by the actuator until it is reset.

2.11 TIMER MODE

Timer mode is used to control the valve movement. This mode allows us to open or close the valve slowly towards the end position after reaching a certain distance with continuous operation.

Configurable Options

- Open timer start Valve Position: The user has to set the valve position at which this Timer mode should go on for Open Command.
- Open ON time : This parameter decides the amount of time (in s) the actuator runs in Open direction before shutting off for Open OFF time (in s). This continues to happen until the respective limit switch is hit (unless the switch is bypassed).
- Open OFF time: This parameter decides the amount of time (in s) the actuator shuts off before running in open direction for Open ON time (in s). This continues to happen until the respective limit switch is hit (unless the switch is bypassed).

- Close timer start Valve Position : The user has to set the valve position at which this Timer mode should go on for Close command.
- Close ON time : This parameter decides the amount of time (in s) the actuator runs in Close direction before shutting off for Close OFF time (in s). This continues to happen until the respective limit switch is hit (unless the switch is bypassed).
- Close OFF time : This parameter decides the amount of time (in s) the actuator shuts off before running in open direction for Open ON time (in s). This continues to happen until the respective limit switch is hit (unless the switch is bypassed).
-

2.12 PROGRAMMABLE RELAYS

As per standard two relays are given for customer end information - Fault Relay & Optional Relay 1. There are about 6-8 more additional relays that have been added along with this module. Each of these relays can be configured for the following 27 faults/statuses as given below.

- List of available relays
 - o Fault Relay
 - o Optional Relay (3 relays)
 - o Latching Relay (2 relays)
 - o Additional Relay(4 relays)
- Available Programmable options are:

o Opened (Open Limit Trip)	o SP Reached (via DAC/MODBUS)
o Closed (Close Limit Trip)	o Selector SW LOCAL
o Remote Local stop	o Selector SW OFF
o Local Stop	o Selector SW REMOTE
o Open Torque Trip	o ESD Pressed
o Close Torque Trip	o 24V DC Fail
o Loss of Phase	o Space Heater Fail
o TH-Trip	o Running Open
o TOLR Trip	o Running Close
o Control Supply Fail	o Remote Selector SW EN
o Phase reversal	o PVST Fail
o Jammed Valve	o Intermediate Pos
o Power ON	o 4-20mA Signal Fail
o Program Mode Indication	

2.13 REAL TIME CLOCK (RTC)

This module has a Real time clock that is used to obtain the time-stamp for Event logging. The RTC can be configured by Auma Utility Software or by manually setting the RTC in Program Mode

settings. The RTC is powered by a Super Capacitor when the power is off which is another added feature of this module. The Super Capacitor takes about 2 hours to charge and can supply power upto 20 days to the RTC.

2.14 POWER SUPPLY

The Power Supply Card used in this module has several new features. The features are as follows:

- Under Voltage Protection
- Over Voltage Protection
- Short Circuit Protection
- Uses Single Transformer with selectable voltage & frequency range
- Voltage Range : 360VAC to 480VAC
- Frequency Range: 47.5Hz to 63Hz.

2.15 SURGE PROTECTION AND LIGHTENING ARRESTER

This module has protection again voltage surges and lightening by using a protection card for 4-20ma/ MODBUS operation. This card is called Surge protection and lightning arrester (SP & LA) card. It is placed between command signal line and Interface (IF) card to eliminate the voltage fluctuations. This card is given as default when Modbus or regulating duty is given.

NOTE: The features supported by your actuator is with respect to the wiring diagram (WDP) provided with it. Please remember that it might not have all the features described in this document.

3. FRONT PANEL DETAILS

This section outlines the front panel details of 3.XMP Actuators. Fig. A shows the picture of the same. The functions of each of these components are discussed below.

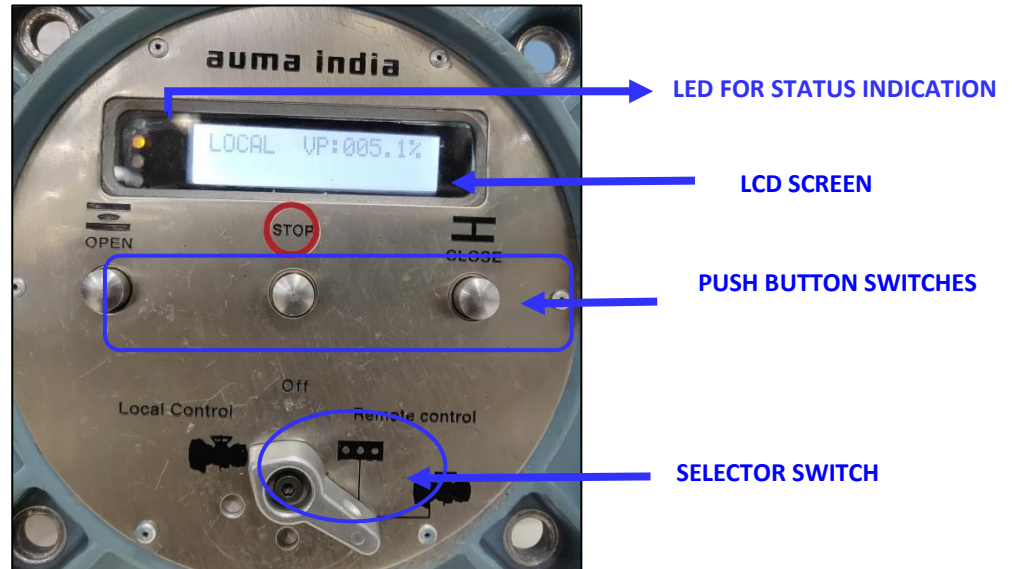

Fig. A: 3.XMP NON-INTRUSIVE WITH BLUETOOTH FRONT PANEL

3.1 Selector Switch

There are 3 modes available; LOCAL, OFF & REMOTE. The mode selection can be done by using the selector switch.

3.2 Push Button Switches

Actuators are made to run in OPEN or CLOSE direction by pressing the respective push buttons and can be stopped in middle during travel by pressing STOP push button. These three push buttons are also used for programming and calibrating the actuator.

3.3 LCD Screen & LEDS

The basic LCD view is split into two lines. The first line shows the status details - The left half shows selector switch position status and the actuator running status alternatively. The right half of the first line represents Valve Position (VP) in terms of percentage. The valve position display feature is optional. If required, an appropriate Electronic Position Transmitter (EPT) must be chosen for this feature. Please contact AUMA India for more information.

The second line is used to represent only faults. The faults/warnings if any toggle in the sequence of occurrence. The details are as shown in the Fig. B.

Information regarding the running indication of the actuator (status) and faults are indicated by the LEDs present on the left side of the LCD screen which is as shown in Fig. B.



Fig. B: 3.XMP NON-INTRUSIVE WITH BLUETOOTH LED & LCD SCREEN

One can configure the four LEDs on the display module to represent different conditions. The default LED settings are as below:

COLOR	INDICATION	MODE
GREEN	●	If LED is blinking then actuator is running in OPEN direction. If LED is continuously ON then actuator is fully OPENED. If LED is OFF – then actuator is in Mid-Travel.
AMBER	●	If LED is blinking then actuator is running in CLOSE direction. If LED is continuously ON then actuator is fully CLOSED. If LED is OFF – then actuator is in Mid-Travel.
RED	●	If LED is continuously ON -- Fault Condition If LED is OFF – No fault Condition
WHITE/BLUE	●	Default: OFF If LED ON: Paired and Connected with Auma India Utility Software/ Whenever BT is connected

4. MODES OF OPERATION

This section describes about the modes available for selection in this module. The options are:

- **MODE 1** - Program mode
- **MODE 2** - Calibration mode
- **MODE 3** - Diagnostic mode

There are several options/settings that are available in each of these modes. These are discussed below.

4.1 PROGRAM MODE

The push buttons on the Front Panel can be used for programming. To enter into PROGRAM MODE, follow the below steps:

Step 1: Keep the selector switch in OFF position



Step 2: Press Open + Close keys together for approximately 6 seconds.



Step 3: Press the STOP key on the display of “Program Mode” as shown in the below figure.



In the program mode, one can choose to configure settings as per custom requirements. The three sub-categories are – General settings, Remote settings and Relay settings. The flowcharts to choose EDIT/VIEW and any one subcategory are given below.

4.1.1 EDIT/VIEW option of PROGRAM MODE

By entering the appropriate password, user can enter into the “**PROGRAM MODE**” for 3.XMP Non-Intrusive with Bluetooth Module as shown in the above flowchart. The features that can be set in this are given in the below flowchart.

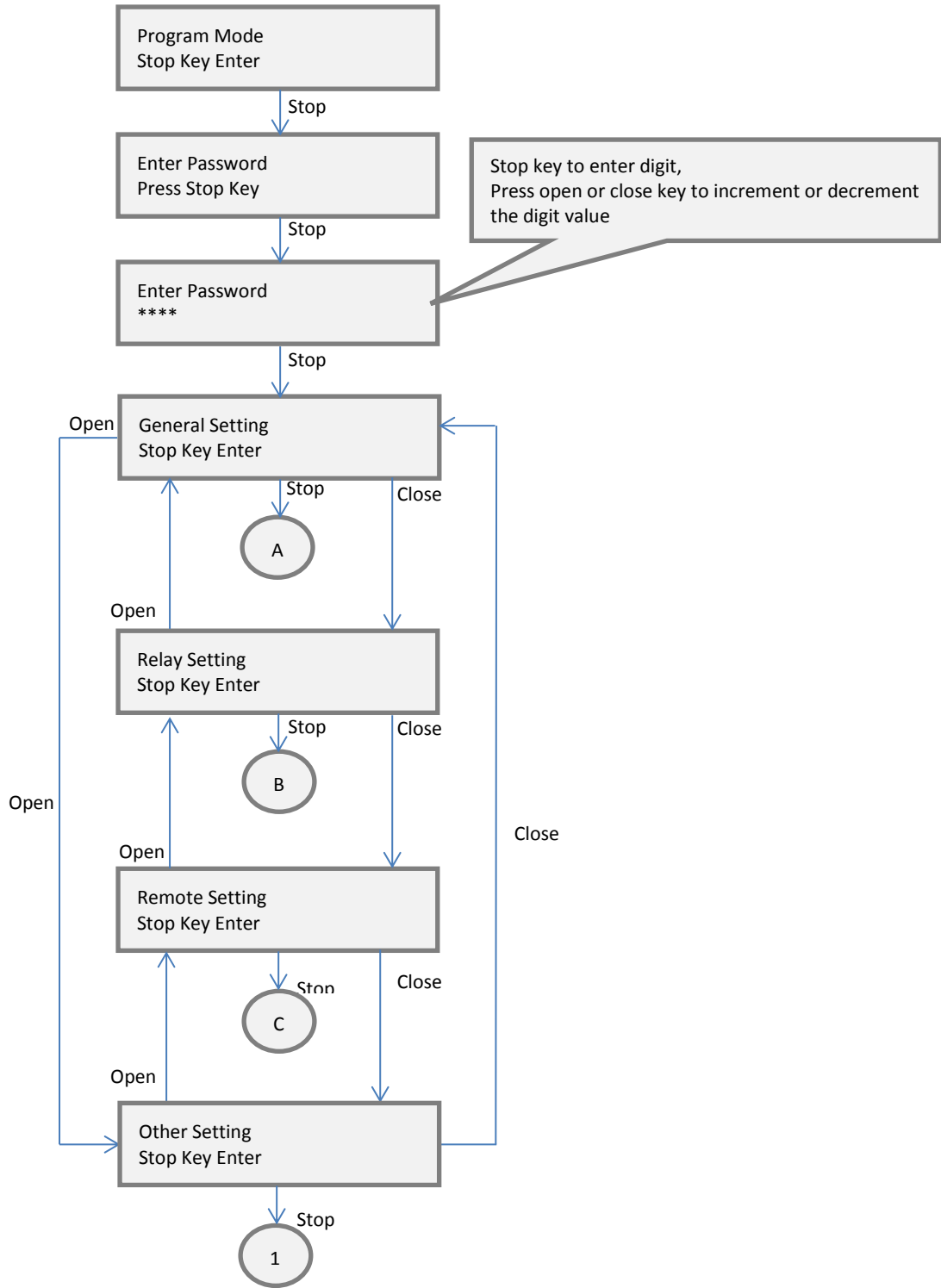

4.1.1.1 General Settings:

Following options can be set by using the Open or Close keys in “GENERAL SETTINGS” of “PROGRAM MODE” for 3.XMP Non-Intrusive with Bluetooth Module.

PROGRAM MODE - General Settings Flowchart

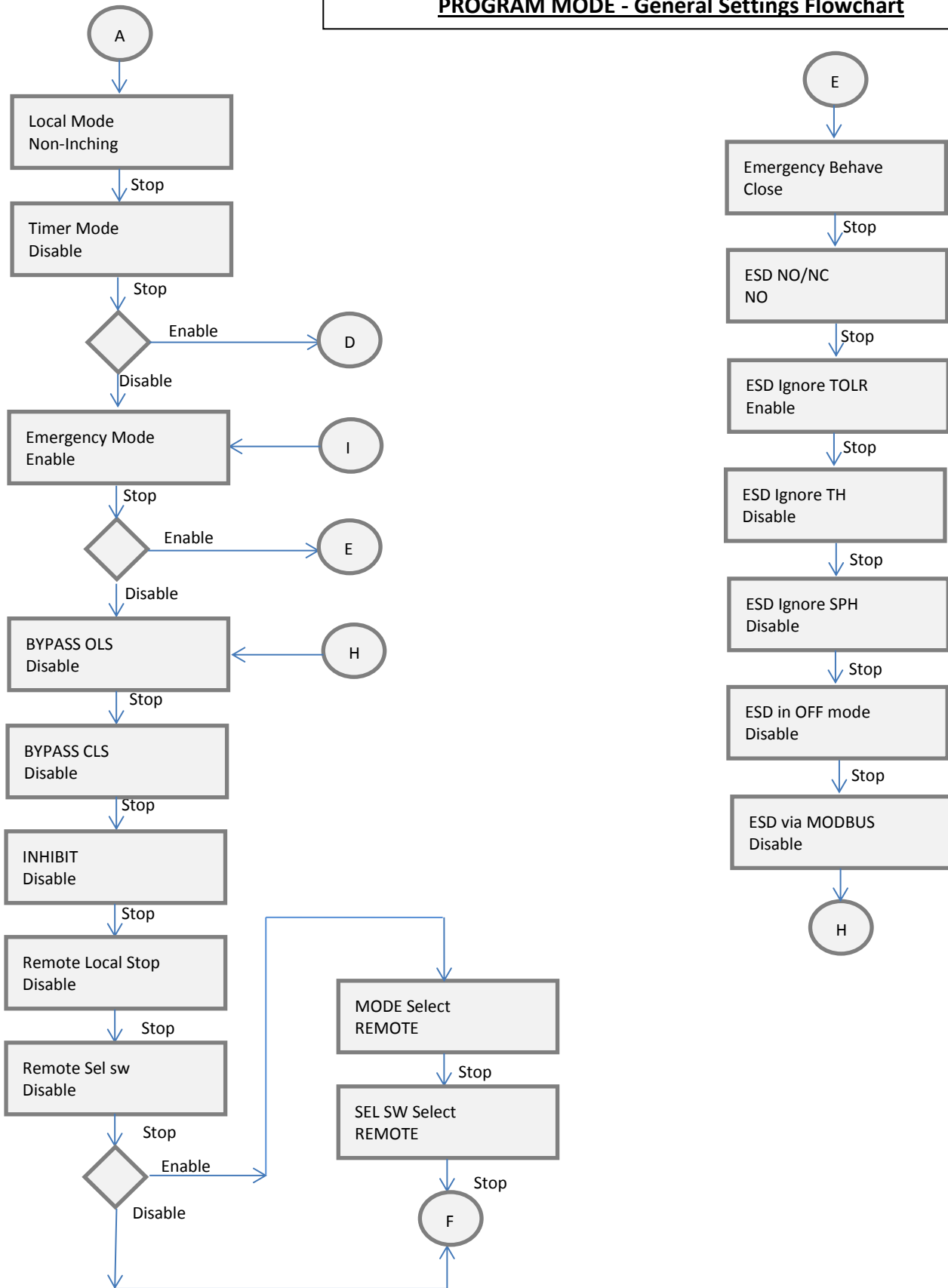

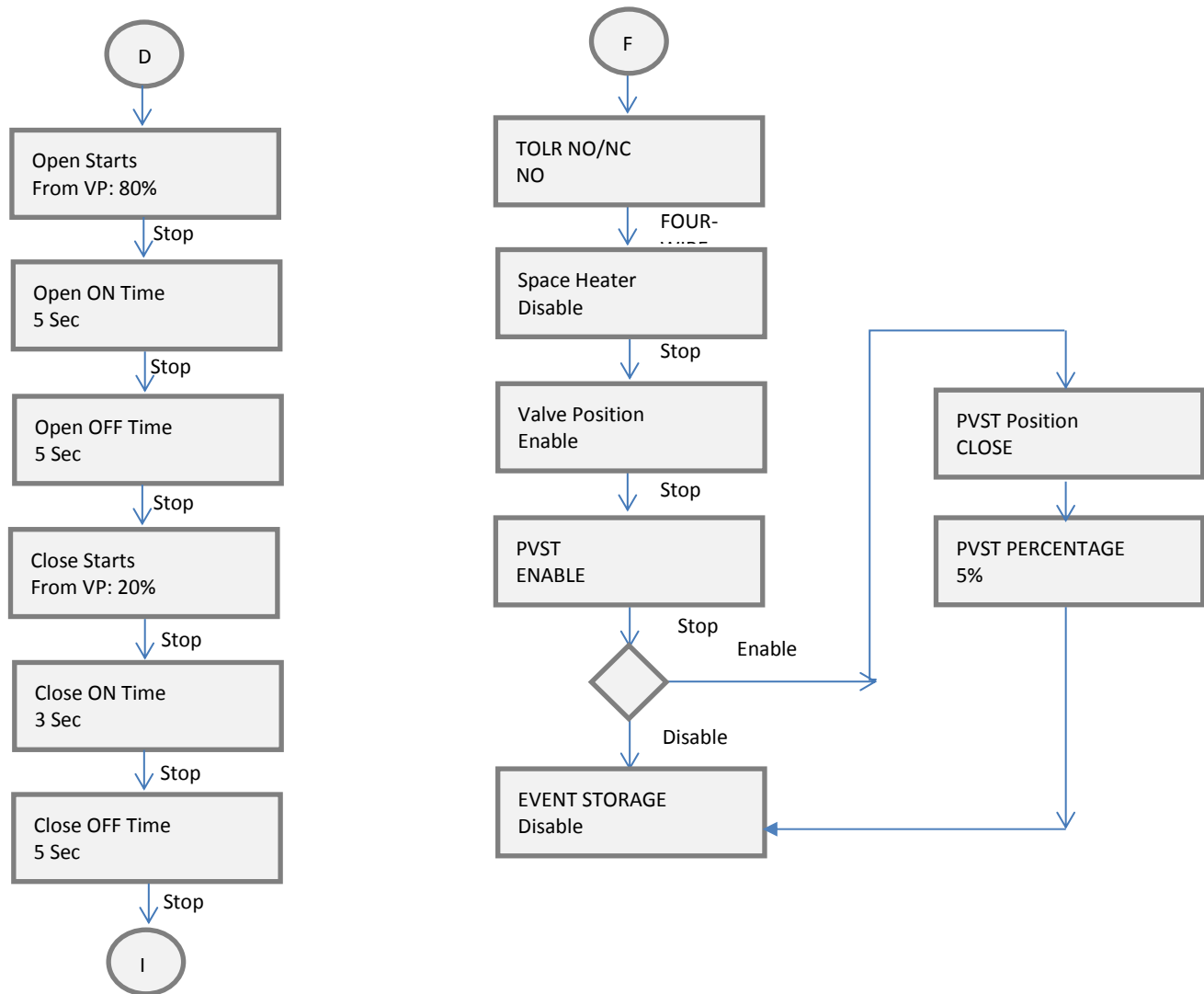

Remote Selector Switch Options:

Enabling Remote Selector Switch in program mode provides an option for the user to select Local/Remote mode through Remote Operation. There are 4 wires available on the user end – (RM/L SS+ & RM/LSS-) and (R/L M SS+ & R/L MSS-). Based on different NO/NC configurations of these wires and the selection of MODE select & SEL Switch Select will give different options as shown in the flowchart below.

4.1.1.2 Remote Settings:

The sub options available in this category are shown below.

- I. Selection of remote inching /non inching
- II. 2-wire remote operation: One of the following option will be available with the default/factory setting.
 - 2-wire make/break
 - 2-wire Modbus
 - 2-wire 4-20mA
 - 4-wire
 - 4-wire negative switching

The flowchart for Remote settings is given below.

PROGRAM MODE - Remote Settings Flowchart

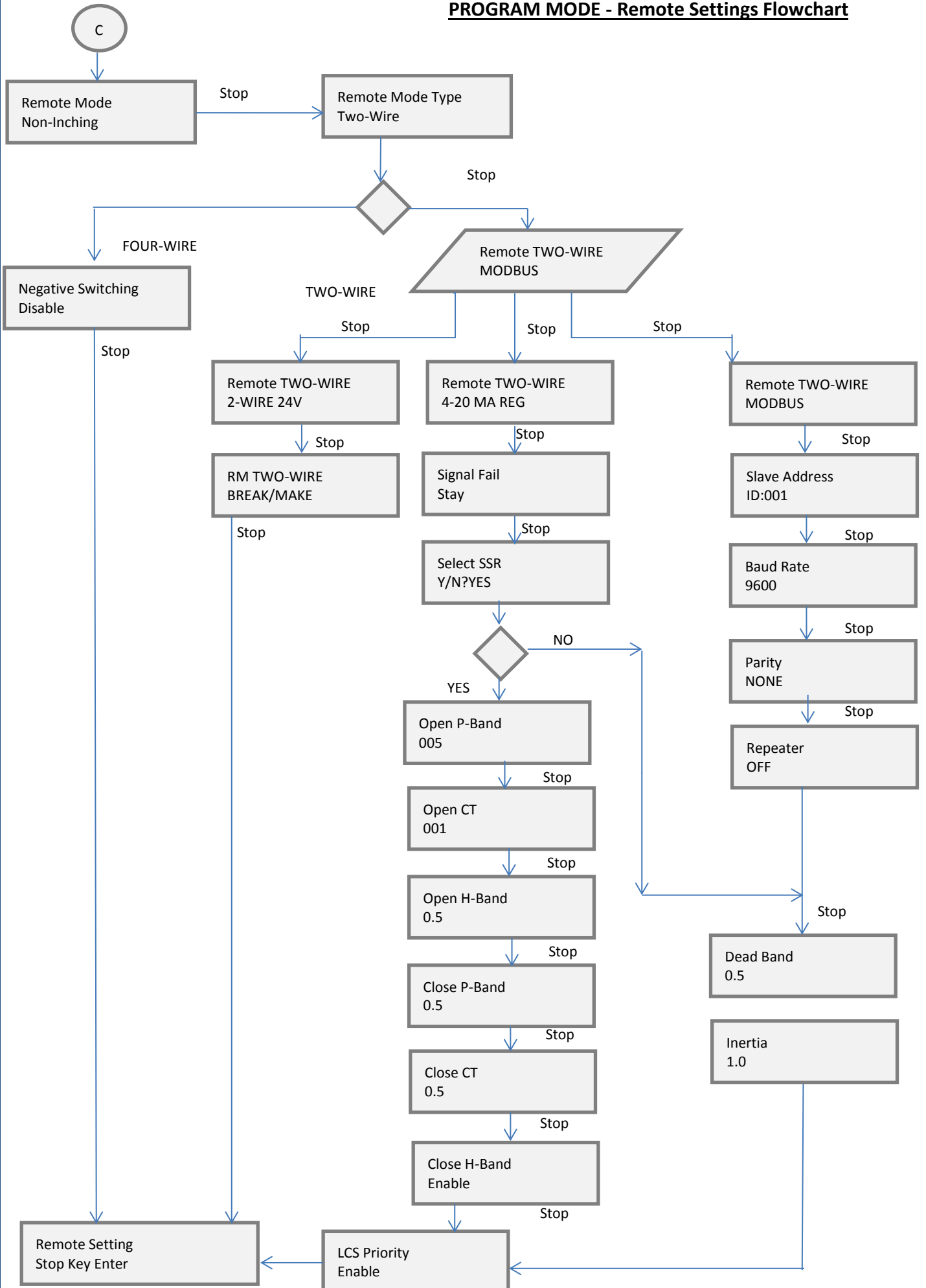

The working of each of the different remote operations is described in the 3.XMP Test Procedure Document: 4 - V3.XMP-39305.

4.1.1.3 Relay Settings:

There are two main relays available for setting different faults/ actuator status. These are Fault relay and Optional Relay.

The default configurations for Fault relay are:

1. 24V supply fail Enable /Disable
2. Control supply fail Enable /Disable
3. Single phasing
4. Open Torque Trip
5. Close Torque Trip
6. Jammed Valve
7. Thermal Switch Trip

The default configurations for Optional relay are: TOLR Trip

There are about 25 features/ conditions available as shown below which the user can choose set for either of the relays. Note that during the relay setting selection, one or multiple option can be selected for the same relay.

1. Opened (Open Limit Trip)
2. Closed (Close Limit Trip)
3. Remote Local stop
4. Local Stop
5. Open Torque Trip
6. Close Torque Trip
7. Loss of Phase
8. TH-Trip
9. TOLR Trip
10. Control Supply Fail
11. Phase reversal
12. Jammed Valve
13. Power ON
14. Program Mode Indication
15. SP Reached (via DAC/MODBUS)
16. Sel SW LOCAL
17. Sel SW OFF
18. Sel SW REMOTE
19. ESD Pressed
20. 24V DC Fail
21. Space Heater Fail
22. Running Open
23. Running Close
24. Remote Sel SW EN
25. PVST Fail
26. Intermediate Pos
27. 4-20mA Signal Fail

Note that the Additional Optional Relays and Additional Relays (Four Numbers) can be configured for the same set of faults as shown in the flowchart below. The default settings are off for all of them. These can be configured in Factory Settings in Diagnostic Mode that will be discussed in section 3.

C

Open->FLT Rly
Close->OPT Rly

F-Rly Opened
YES/NO?

F-Rly Closed
YES/NO?

F-Rly Remote Local Stop
YES/NO?

F-Rly Local Stop
YES/NO?

F-Rly Open torque trip
YES/NO?

F-Rly Close torque trip
YES/NO?

F-Rly Loss of Phase
YES/NO?

F-Rly TH- Trip
YES/NO?

F-Rly TOLR Trip
YES/NO?

F-Rly Cntrl spl fail
YES/NO?

Phase Reversal
YES/NO?

Jammed Valve
YES/NO?

J

Opt-Rly Opened
YES/NO?

Opt -Rly Closed
YES/NO?

Opt -Rly Remote Local Stop
YES/NO?

Opt -Rly Local Stop
YES/NO?

Opt -Rly Open torque trip
YES/NO?

Opt -Rly Close torque trip
YES/NO?

Opt -Rly Loss of Phase
YES/NO?

Opt -Rly TH- Trip
YES/NO?

Opt -Rly TOLR Trip
YES/NO?

Opt -Rly Cntrl spl fail
YES/NO?

Opt -Rly Phase Reversal
YES/NO?

Opt -Rly Jammed Valve
YES/NO?

K



4.1.1.4 Other Settings:

There are two different options in other settings

RTC Setting

Intermediate Position Setting

RTC Setting

Navigate to **“SET RTC”** in ‘Other Settings’ inside the Program mode. Press stop key to enter the RTC setting. First setting will be SET Date Press Open or Close key to increase or decrease the date respectively. Press Stop to move to Next setting.

Follow the above procedure to Month, Year, Hour, Minute and Day.

After setting Day Press Stop key, you will get a menu to save current time to reset RTC. Select YES or NO by pressing Open or Close key respectively. Press stop to exit the menu.

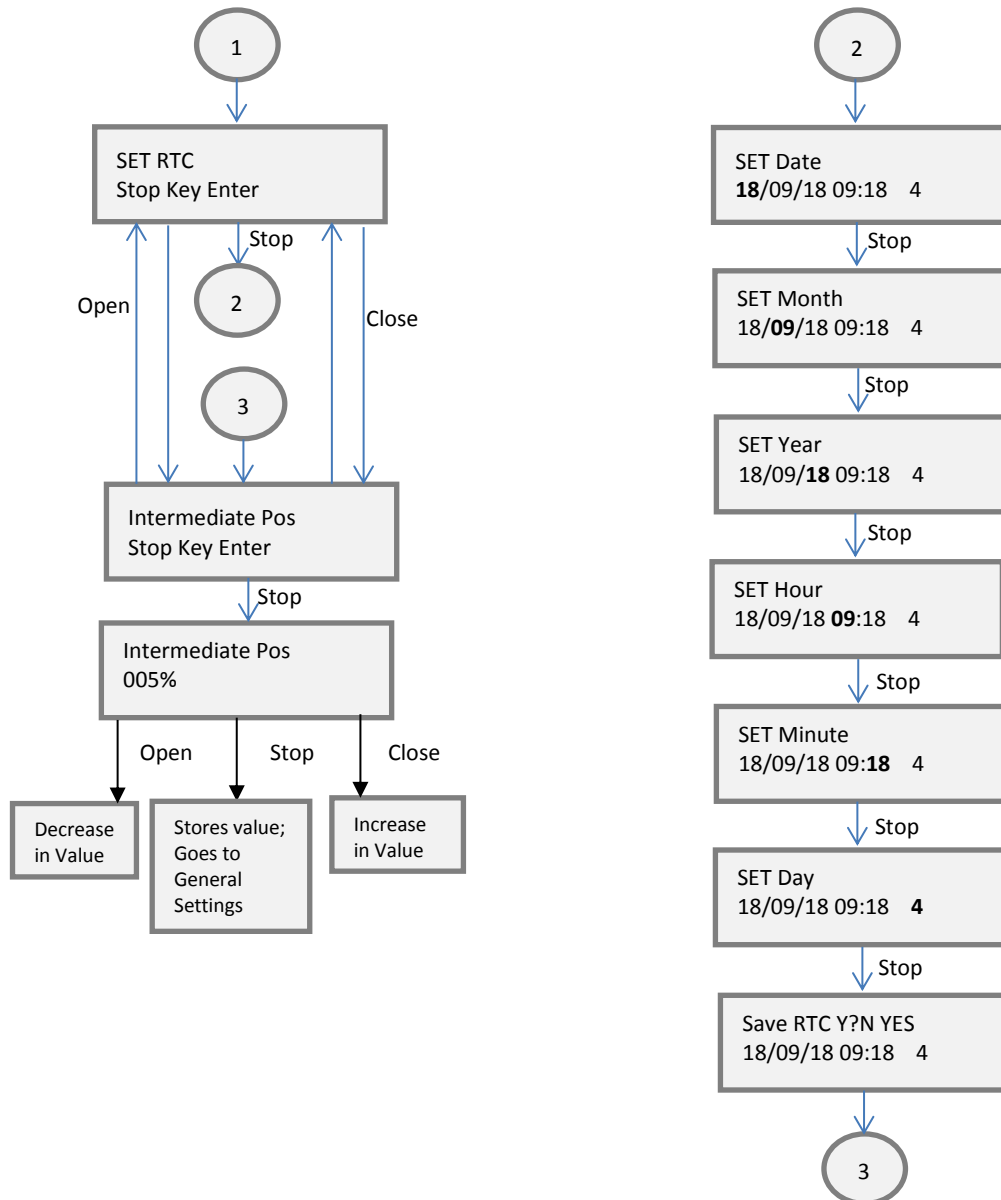

Intermediate Position Setting

This setting is used to operate a relay to indicate the intermediate valve position. After entering **“Intermediate Pos”** from other options you can select the position from 1 to 99 and press stop to save. Any of the relays can be configured to show this position. The relay can be configured from relay settings mentioned above.

4.2 CALIBRATION MODE

In this mode, the following three key parameters can be calibrated:

- I. Potentiometer Calibration (“Pot Calib”)
- II. Position Feedback (E2: DAC Output Calibration (“DAC Calib”)
- III. Command signal Input(E1: 4 – 20 mA Calibration (“4-20mA Calib”)

To enter into the Calibration Mode follow the below steps:

Step 1: Keep the selector switch in OFF position



Step 2: Press Open + Stop keys (together) approximately 6 seconds



Step 3: Press the STOP key on the display of “Calibration Mode” as shown below.

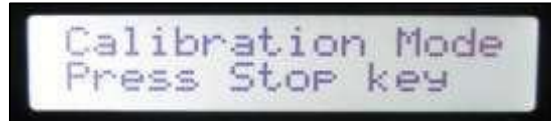

The below flowchart depicts how to enter into different calibration modes. For clear understanding of all options of CALIBRATION MODE, refer to the detailed flowcharts presented in the following sections.

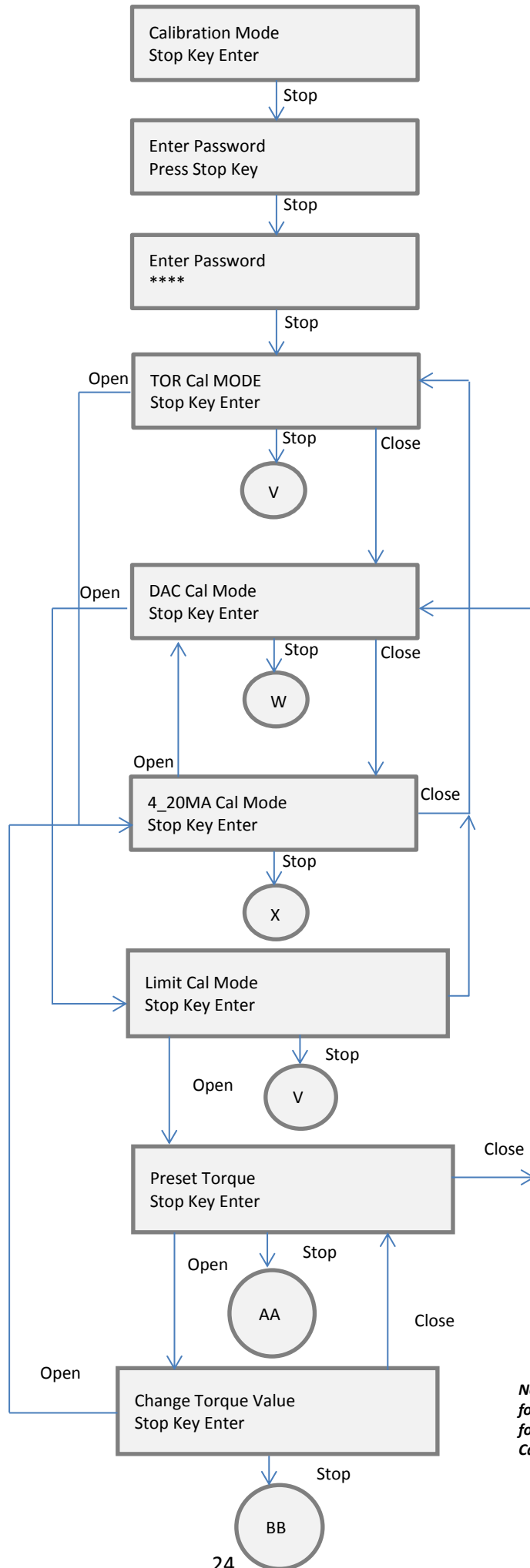

Note: Refer to the detailed flow chart followed by the explanations below for clear understanding of the Calibration Mode

4.2.1 LIMIT CALIBRATION

The flowchart for this calibration is as given below. The procedure is as discussed below.

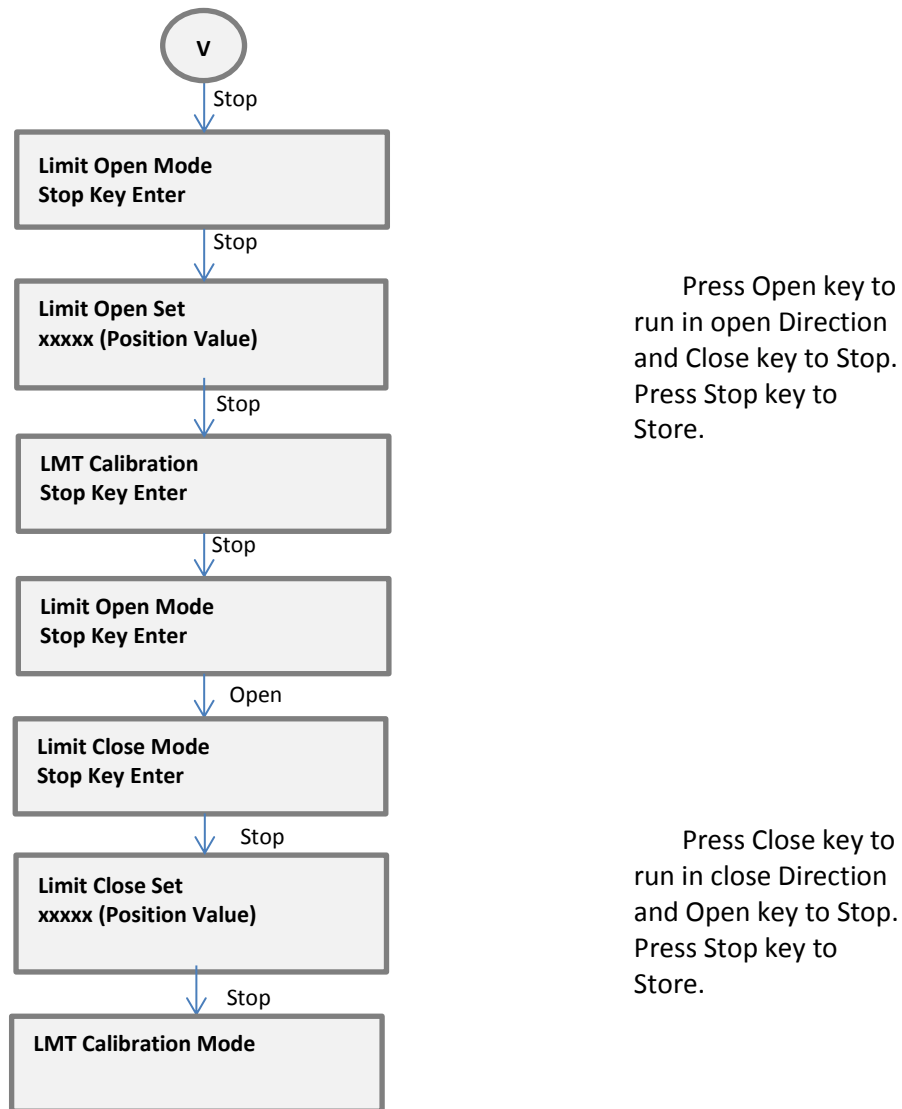

In the Calibration mode, press STOP key to enter into LIMIT Calibration.

LIMIT OPEN CALIBRATION

- The LCD screen shows the current value of Open Limit.

Limit Open Set
xxxxx

- Press OPEN push button to run the actuator in Open direction. Press CLOSE button to stop the actuator before reaching end travel.
- Engage Manual operation. Turn the hand wheel until valve is completely Opened.
- Press STOP key to accept the Open Limit Value.

LIMIT CLOSE CALIBRATION

- a. The LCD screen shows the current value Close Limit.

Limit Close Set
xxxxx

- b. Press CLOSE push button to run the actuator in Close direction. Press OPEN button to stop the actuator before reaching end travel.
- c. Engage Manual operation. Turn the hand wheel until valve is completely Closed.
- d. Press STOP key to accept the Close Limit Value.

** Note: Please ensure Limit Close Set and Limit Open Set (xxxxx) are in the range **8000 - 25000**. Please contact AUMA Service for any further assistance.

4.2.2 DAC CALIBRATION

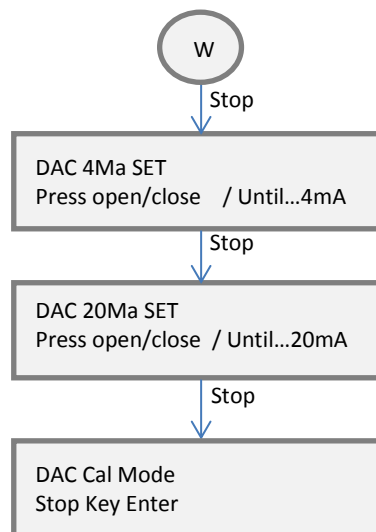

The flowchart for DAC calibration is given above and the procedure for the same is as discussed below. In the Calibration mode, use the below steps to enter into DAC calibration

- a. Press STOP key when the following screen appears on LCD

Calibration Mode
Press Stop Key

The below screen appears on the successful entry of password.

**TOR Cal Mode
Press Stop Key**

- b. Press OPEN push button or CLOSE push button until DAC Calibration menu appears as below,

**DAC Cal Mode
Press Stop Key**

- c. Press STOP push button to select and enter into the DAC calibration mode
- d. Now connect the multi meter/current reading meter (ammeter) to IO+ and IO- points. The following messages are displayed on the screen

**DAC 4mA Set
Press open/close key**

**DAC 4mASet
Until.....4mA**

- e. Press OPEN push button to increment the DAC output value or press CLOSE push button to decrement the DAC output value until it reaches 4mA (see the display on the multi meter/ammeter).
- f. On reaching 4mA (as read on current meter) press the STOP push button to store the value. This completes the DAC-4mA Calibration. Now the following messages will toggle on the LCD display.

**DAC 20mA Set
Press open/close key**

**DAC 20mA Set
Until.....20mA**

- g. Press OPEN push button to increment the DAC output value or press CLOSE push button to decrement the DAC output value until it reaches 20mA (see the display on the multi meter/ammeter).
- h. On reaching 20mA (as read on current meter) press the STOP push button to store the value. This completes the DAC-20mA Calibration.

4.2.3 4-20mA Calibration

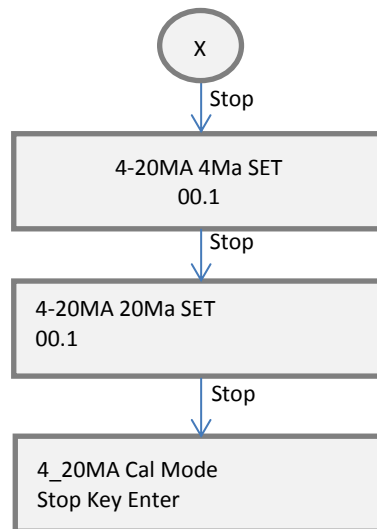

The flowchart for 4-20mA Calibration is as shown above and the procedure is discussed below. In the Calibration mode, use the below steps to enter into 4-20mA calibration

- a. Press STOP key when the following screen appears on LCD

Calibration Mode
Press Stop Key

- b. Press OPEN push button or CLOSE push button until it displays the below screen

4-20 mA Cal Mode
Stop Key Enter

- c. Press OPEN push button to select 4-20mA calibration and enter into the 4-20mA calibration mode
- d. Now use the current source for 4-20mA input; the input to be connected to the terminals II+ & II-. The following message is displayed on the screen

4-20MA 4Ma SET
4.0

- e. Apply current from the source until 4.0 mA is displayed on the screen. Press STOP push button to store the value.
- f. Now the below message appears on the screen

4-20MA 20 Ma SET
20.0

- g. Apply current from the source until 20.0 mA is displayed on the screen. Press STOP push button to store the value.

4.2.4 Change Torque Value

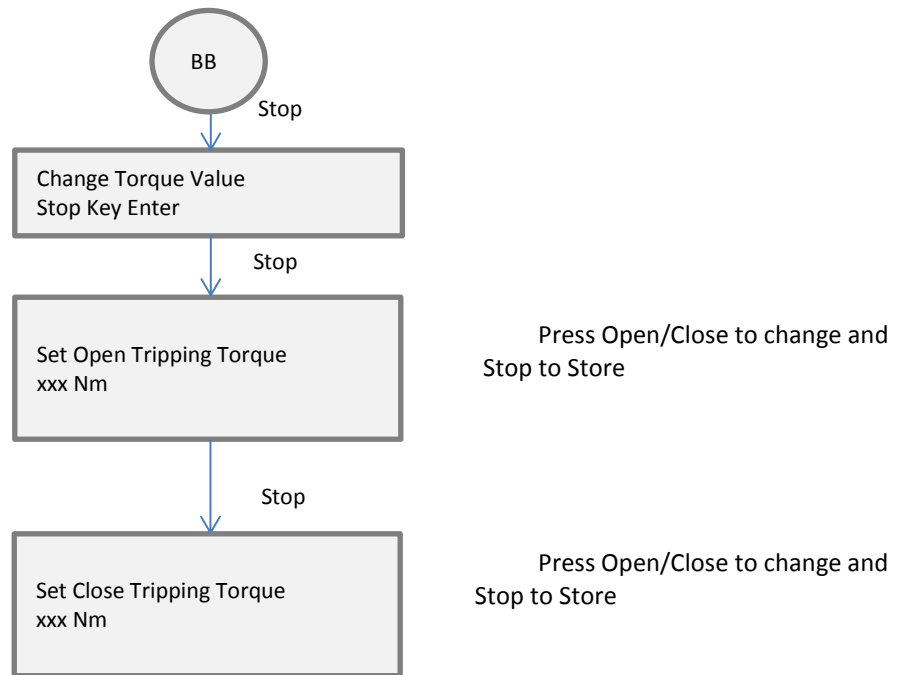

- a) Press STOP key when the following screen appears on LCD

Calibration Mode
Press Stop Key

Enter the password and upon successful password entry, the below screen appears.

TOR CAL Mode
Press Stop Key

Do not press Stop key, instead press OPEN key until the following screen appears.

- b) Press OPEN Key until the following screen appears

Change Tor Value
Stop Key Enter

- c) Open Tripping Torque and Close Tripping Torque can be changed by using Open/Close keys.

Set Open Tripping Torque
xxx Nm

Set Close Tripping Torque
xxx Nm

4.2.5 Preset Torque

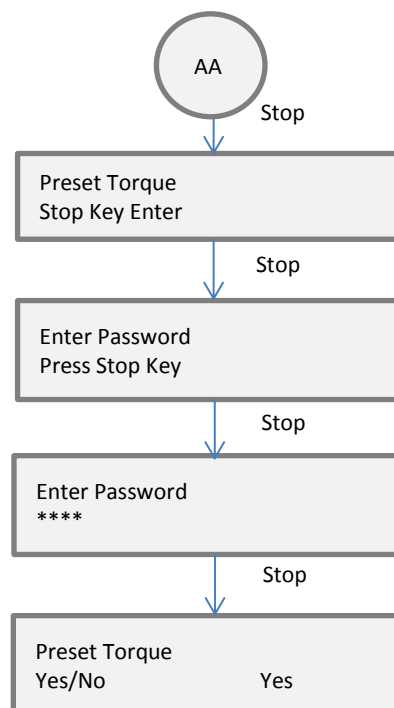

** Note : For Details regarding Preset Torque please contact AUMA Service Team.

4.2.6 SSR Tuning for Regulating Duty

Solid state relays can be used in place of contactor in 3.XMP module for better precision. To identify if the actuator is Solid State Relay based check the firmware version. Firmware version ending with “S” is a SOLID STATE RELAY actuator.

In Solid state relay we have the following important parameters which need setting.

1. **P Band in terms of %:** P band is the band set onset of which starts the fine control action. Span of P Band is from 1% to 10%. This is the start of the control cycle (cycle time). Ref. fig.1
2. **H Band (Hysteresis band) in terms of %:** H band (Hysteresis band) the band in which no control action takes place. If the valve position is within this band there will be no movement. The span of H Band is from 0.1% to 10%. This is almost near to the set value. Ref. fig.1.
3. **Duty cycle in terms of sec:** The total duration for which P band operates. The on time & off time of system depends on the P band. The span of Duty cycle is 1 sec to 5 sec. Ref. fig 1

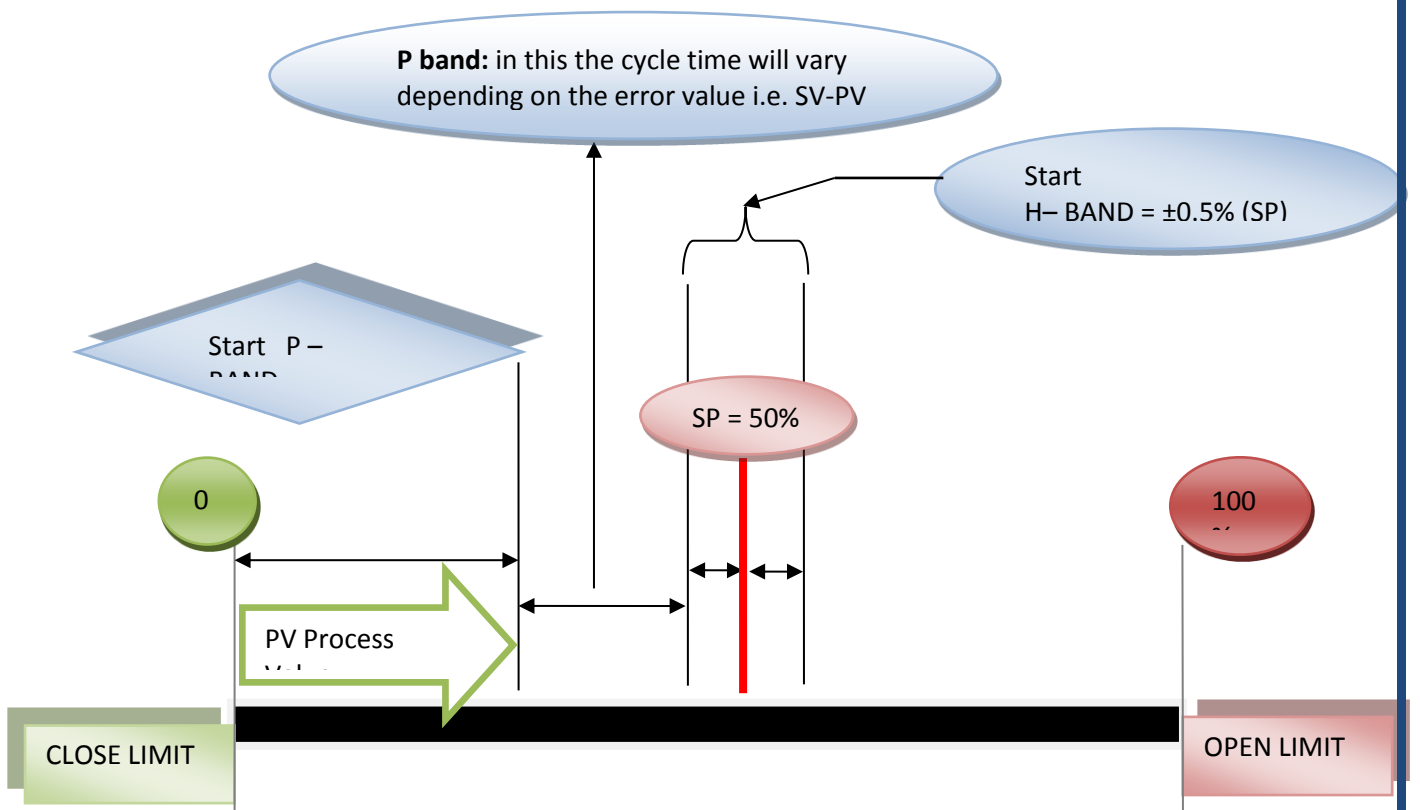
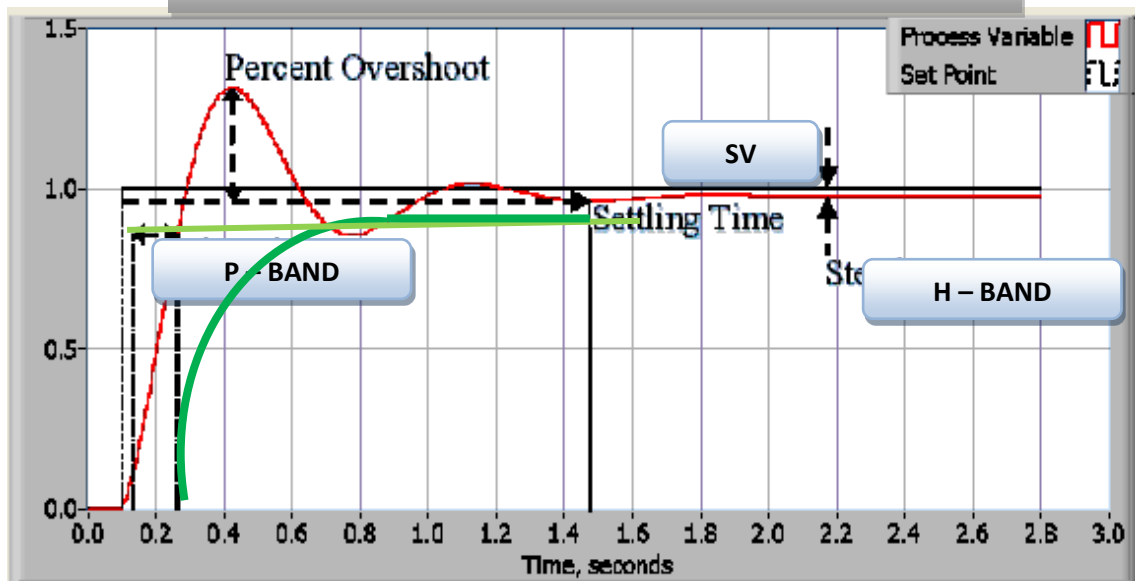

Fig.1: Example for Close to open direction with Set Point 50%



PROCEDURE TO TUNE SOLID STATE CONTROLS

Default setting:

SL.NO	PARAMETER	OPEN SIDE	CLOSE SIDE
1	P band	5%	5%
2	H band	0.5%	0.5%
3	Duty Cycle	1 sec	1 sec

The above values are optimally set for the actuator as default settings. They can be changed if required for the following conditions:

- The P band is to be increased in case the PV (process value/ valve position) increases the SV (set valve) and the actuators goes into hunting between Open and close and settles at the SV (set value).
- Duty Cycle will depend on the P band. P band & Duty cycle are proportional i.e. larger the P band larger will be Duty Cycle.
- H band (Hysteresis band) is to be increased in case there is continuous hunting and the actuator does not stop.

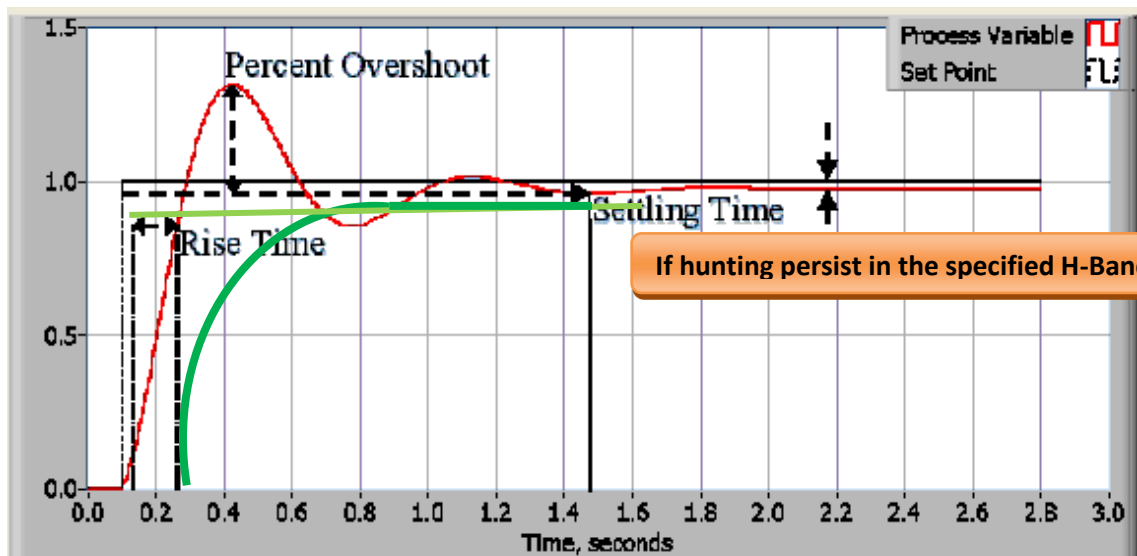

PROCEDURE TO PROGRAMMING SOLID STATE RELAY CONTROLS

The programming instructions for SSR are as given in PROGRAM MODE – Remote Settings Flowchart above in section 4.1.1. The same instructions are also given below.

Manual for entering into settings:

Step 1: Put Selector switch in OFF Position

Step 2: Press OPEN and CLOSE Key Together for Approximately 6 Seconds

Step 3: After entering into program mode follow the flow chart as shown

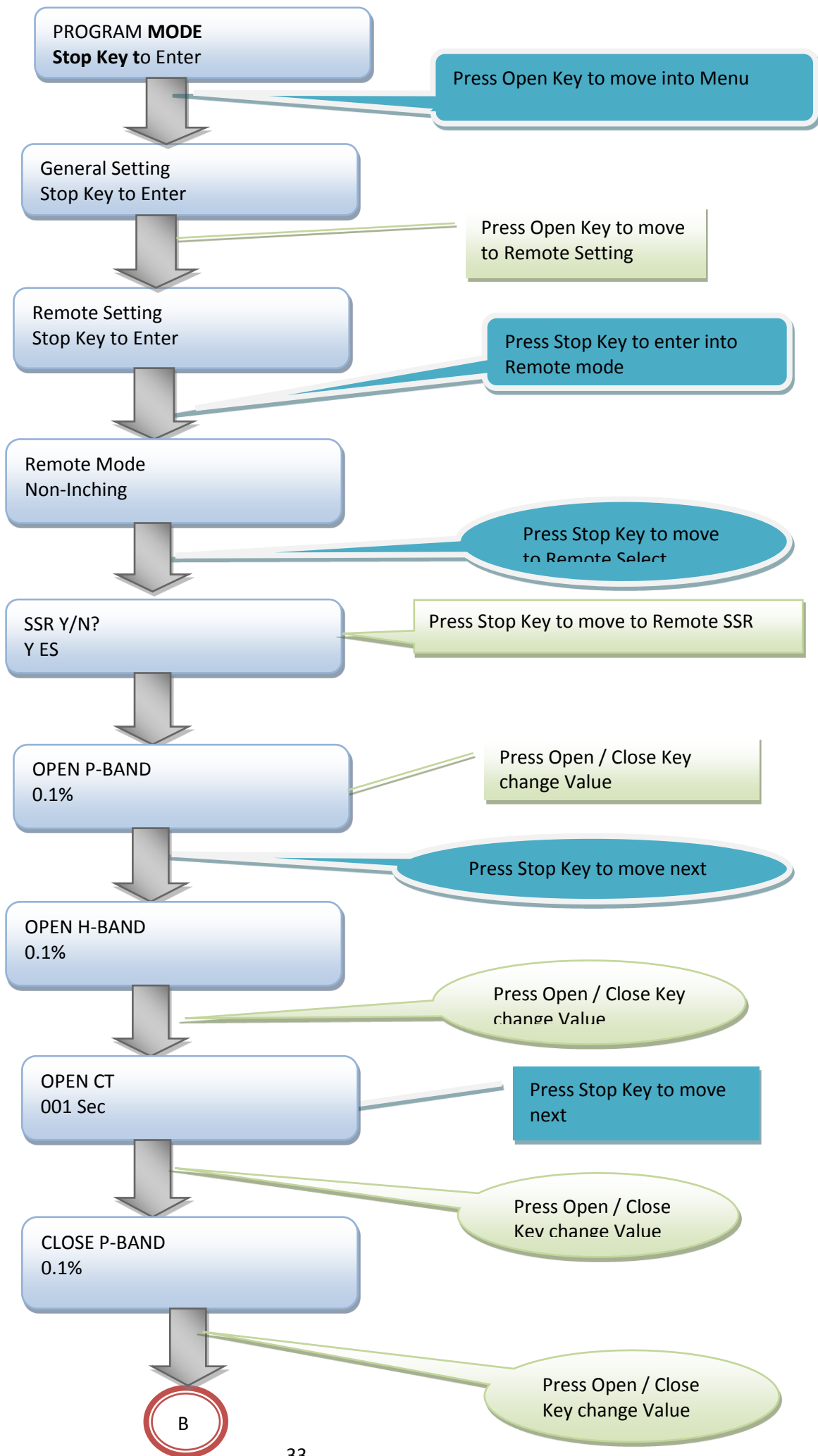

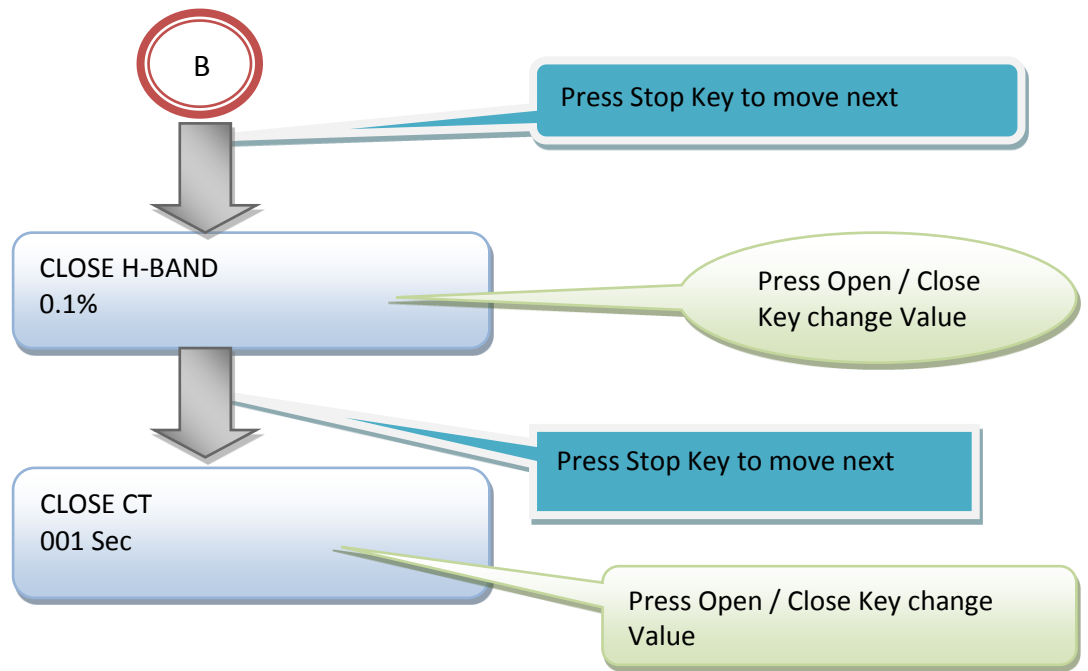

Sample Tuning Values:

SL.NO	ACTUATOR	RPM	PARAMETER	OPEN SIDE	CLOSE SIDE
1	SA 12	45 RPM	P band	5%	5%
2			H band	0.5%	0.5%
3			Duty Cycle	1 sec	1 sec

4.3 DIAGNOSTIC MODE

This mode is used to mainly diagnose the control module and its configurations.

To Enter Diagnostic Mode press stop and close key together for approximately 6 seconds when the actuator is the off mode as shown below.

Step 1: Keep the selector switch in OFF position



Step 2: Press Close + Stop keys (together) approximately 6 seconds



Step 3: Press the STOP key on the display of "Diagnostic Mode" as shown below.



From Diagnostic mode you can get the following values: The software version installed, the raw RTC and POT values etc. can be checked here. One can give commands and check if these values increase/decrease accordingly. The RTC reading can be verified and checked if it is correct. The IN-PHASE, OUT-PHASE and LOSS OF PHASE detection can be verified. A factory reset to set the system into default settings according to the customer specifications can be carried out. Besides this, this module has a Factory settings option that only under the scope of Auma India Employees that has several software configurable options.

DIAGNOSTIC MODE – Software Flowchart

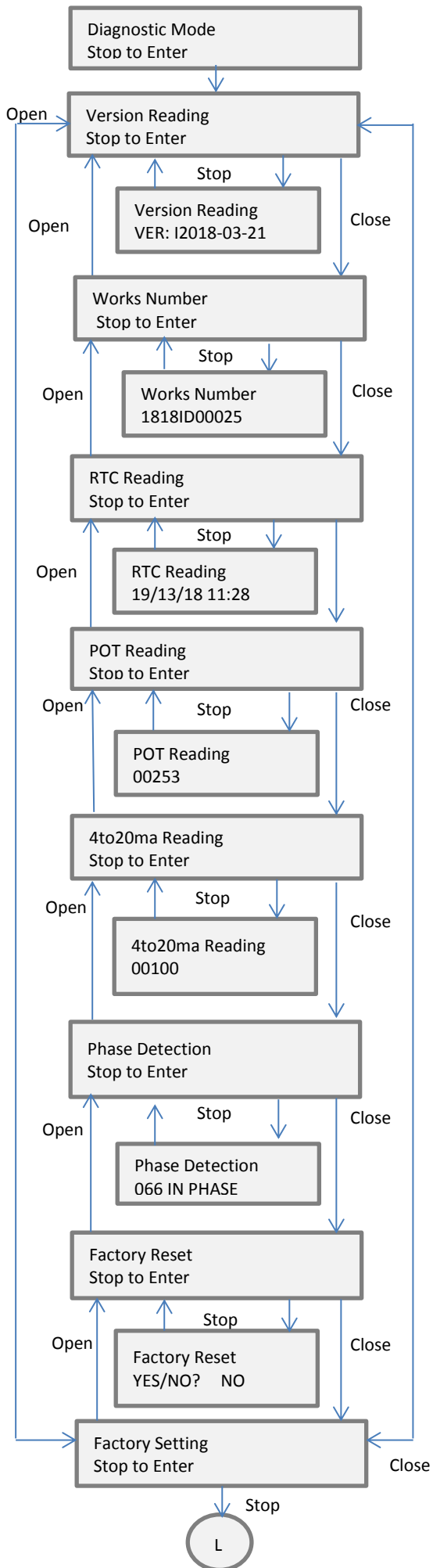

NOTE: Flow-Control L of Factory Settings under Diagnostic Mode is in the scope of Auma India Engineers only.

5. TOPOLOGY CONNECTION

Topology is a pattern in which DCS/AIMS and several actuators are connected in a network. The figures below show the two main topologies – Line and Loop - used to connect our actuators for MODBUS communication. The figures below represent the same. This configuration for Line and Loop is decided by the DIP switch settings in the new IF card.

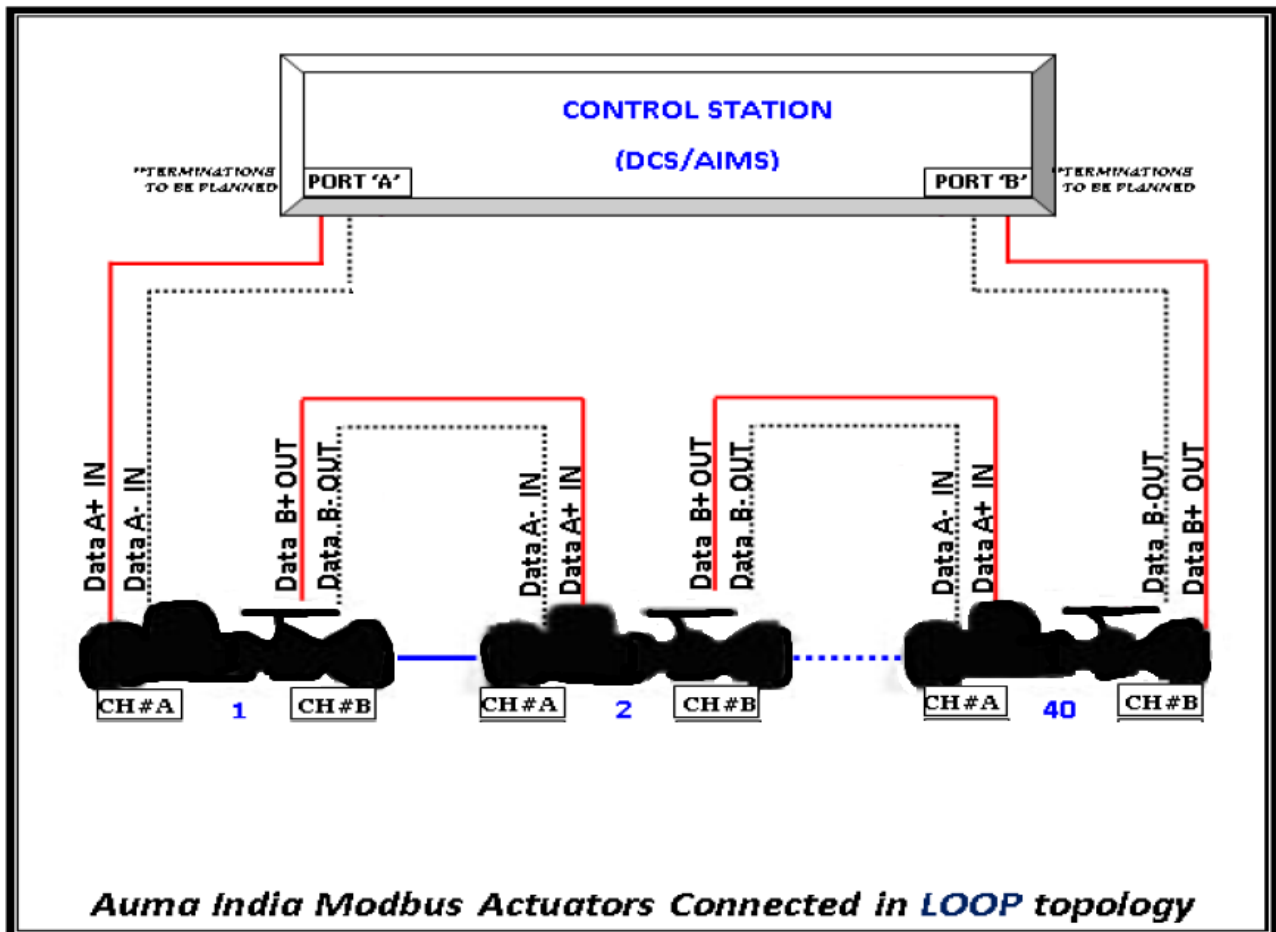

DIP SWITCH SETTING

The table for DIP switches selection is as given below. If termination is required for Channel A/Channel B in line topology, then dip switch 1/ 2 should be on respectively. All the dip switch should be put on for LOOP topology. This configuration takes care of all the terminations that are to be carried out for MODBUS communication.

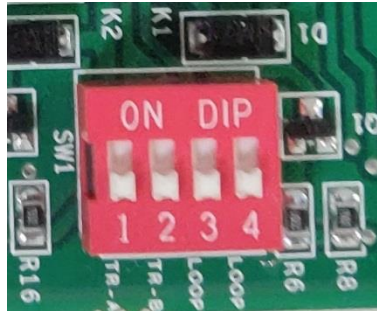

DIP SWITCH	LOOP TOPOLOGY	LINE TOPOLOGY
1	ON	TO BE PUT "ON" IF TERMINATION IS TO BE DONE : CHANNEL A
2	ON	TO BE PUT "ON" IF TERMINATION IS TO BE DONE : CHANNEL B
3	ON	OFF
4	ON	OFF

6. REGISTER DETAILS FOR MODBUS COMMUNICATION

Modbus is a two-wire serial communication protocol that is used for information exchange between DCS/AIMS and our actuators. The details needed for the Modbus communication such as Function Code, Address, Data to be written is listed below.

Function Code Details (as implemented by AUMA):

DESCRIPTION	VALUE
1. READ COIL STATUS	0x01
2. READ INPUT STATUS	0x02
3. READ HOLDING REGISTERS	0x03
4. READ INPUT REGISTERS	0x04
5. FORCE SINGLE COIL	0x05
6. FORCE MULTIPLE COIL	0x0F
7. PRESET SINGLE REGISTER	0x06
8. PRESET MULTIPLE REGISTERS	0x10
9. DIAGNOSTICS	0x08
a. LOOP BACK	0x00
b. CLEAR COUNTERS	0x0A
c. RETURN BUS MESSAGE COUNT	0x0B
d. RETURN BUS COMMUNICATION ERROR COUNT	0x0C
e. RETURN BUS EXCEPTION ERROR COUNT	0x0D
f. RETURN SLAVE MESSAGE COUNT	0x0E
g. RETURN SLAVE NO RESPONSE COUNT	0x0F

Function Code 1, 5 & 6: The register details for read & write operations associated with the function codes 1, 5 & 6 (coil status) are as below.

DESCRIPTION	ADDRESS IN HEX
1. REMOTE OPEN	0x0000
2. REMOTE CLOSE	0x0001
3. REMOTE SET POINT	0x0002
4. REMOTE SW POSITION	0x0020
5. OFF SW POSITION	0x0021
6. LOCAL SW POSITION	0x0022

Note: The data values of the function code 1, 5 & 6 are to be indicated in binary (1/0).

Function Code 2: The register details associated with the function code 2 (Read Input Status) are as below.

DESCRIPTION	ADDRESS IN HEX
OPEN POSITION	0x0000
CLOSE POSITION	0x0001
SET POINT REACHED	0x0002
RUNNING OPEN	0x0004
RUNNING CLOSE	0x0005
THERMAL FAULT	0x0008
REMOTE SW POSITION	0x000A
LOCAL SW POSITION	0x000B
LSO	0x000C
LSC	0x000D
TSO	0x000E
TSC	0x000F

Note: The data values of the function code 2 is to be indicated in binary (1/0).

Function Code 4: There are two registers present with the address 0x03E8 & 0x03E9 from which the status details can be got. The details of the data associated with each address are as tabulated below.

3.XMP-Version 1.0			3.XMP-Version 2.0			
ADDRESS	0x3E8	0x3E9	0x3E8	0x3E9	0x3EA	
DATA DETAILS			DATA DETAILS			
BIT POSITION	DESCRIPTION		DESCRIPTION			
0	LOCAL POSITION	TSC	LOCAL POSITION	TSC	Valve Position (0-1000)	
1	REMOTE POSITION	TSO	REMOTE POSITION	TSO		
2	RUNNING OPEN	LSC	RUNNING OPEN	LSC		
3	RUNNING CLOSE	LSO	RUNNING CLOSE	LSO		
4	STOPPED	LOCAL POSITION	STOPPED	LOCAL POSITION		
5	OPENED POSITION	REMOTE POSITION	OPENED POSITION	REMOTE POSITION		
6	CLOSED POSITION	LOSS OF PHASE	CLOSED POSITION	LOSS OF PHASE		
7	TSO	TH FAULT	TSO	TH FAULT		
8	TSC	COMMON FAULT	TSC	COMMON FAULT		
9	TH FAULT	PHASE REVERSE	TH FAULT	PHASE REVERSE		
10	TOLR	RUNNING CLOSE	TOLR	RUNNING CLOSE		x
11	JAMMED VALVE	RUNNING OPEN	JAMMED VALVE	RUNNING OPEN		x
12	-	ESD-HARDWIRED	PHASE SEQ. ERROR	ESD-HARDWIRED		x
13	PHASE SEQ. ERROR	SET POINT REACHED	SET POINT REACHED	SET POINT REACHED		x
14	FAULT	CLOSED	FAULT	CLOSED	x	
15	PROGRAM MODE	OPENED	LCS ACTIVATED	OPENED	x	

Function Code 3, 7 & 8: The holding register details for read & write operations associated with the function codes 3, 7 & 8 (holding registers) are as below;

ADDRESS		DATA			
DESCRIPTION	VALUE	RANGE (MIN-MAX)	STD. VALUE	NOTE (MEANING)	
REMOTE CONTROL	0x3E8			BIT 8=1	OPEN
				BIT 9=1	CLOSE
				BIT 12=1	STOP
				BIT 0=1	MODBUS ESD
				BIT 10=1	SET POINT BIT
READ VALVE POSITION	0x3E9	0-1000			
SET VALVE POSITION	0x3EA	0-1000			

7. TROUBLESHOOTING

The RED LED in the LED card indicates the FAULT. To identify the fault, check the status displayed on the LCD/relay status. Following are the typical displays of the FAULT condition and the trouble shooting methods to resolve those issues.

I. DISPLAY-“24V supply fail”

TROUBLESHOOTING:

- a. Check whether FRC cable is properly connected between CPU card and Power Supply card.
- b. Measure the DC voltage between ‘+’ and ‘-’ terminals in Customer Terminal Compartment using a multimeter. Here we are supposed to get 24VDC. If no voltage is coming, then measure the resistance between those terminals using a multimeter by disconnecting the MAINS. If there is a dead short, then replace Power Supply Card.

II. DISPLAY- “Single Phase”

TROUBLESHOOTING:

- a. Ensure that the MAINS 3 phase input supply voltage and frequency of operation is matching the ratings mentioned on the name plate.
- b. This module indicates Single Phase fault when only Y-phase is missing.
- c. Check if there is any discontinuity between the power terminal and transformer card J1 – Y Terminal.
- d. Check for any loose contact/discontinuity in the 8-pin Mini-Fit MOLEX connectors between the fuse and the transformer.
- e. Check whether FRC cable is properly connected between CPU card and Power Supply card.

III. DISPLAY- “TH Switch Trip”

TROUBLESHOOTING:

- a. Check the motor Thermo switch continuity; if continuity is not there then we have to replace the motor.
- b. If the motor thermo switch continuity is there then, check the continuity between wires with ferrule TH and F1 of the J6 on CPU card; If there is no continuity then check the wiring error.
- c. After the above two corrections, if the same error message display continues, then replace the CPU card.

IV. DISPLAY- "TOLR Trip"

TROUBLESHOOTING:

- a. Disconnect the supply to actuator and check whether TOLR is tripped; if yes then reset TOLR using reset switch as shown in figure D below.

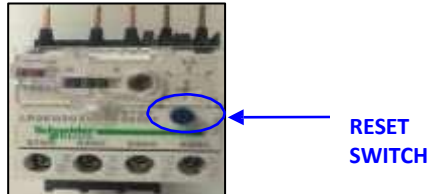

Fig. D: TOLR Trip

- b. Check the continuity between the input and output terminals of TOLR, if there is no continuity then TOLR is faulty, replace the TOLR.
- c. If TOLR is not tripped and the error message continues then check the TOLR selection NO/NC under program mode; verify wires with ferrule 95 and 96 coming from J6 on Power Supply card are connected properly to TOLR's respective contacts depending on NO (Terminals-97, 98) or NC (Terminals-95, 96). Check continuity for these wires from TOLR terminals to J3 connector of Power Supply card.
- d. If continuity is present but still TOLR trip is showing then check FRC Cable is connected properly between Power supply card and CPU Card.
- e. If still problem continues then replace CPU and POWER cards.

V. DISPLAY- "Space Heater fault"

TROUBLESHOOTING:

- a. Check whether Fuse -F4 is blown; If yes, replace with good slow blowing fuse of 150mA, 250V rating.
- b. With the help of multimeter measure the Space heater voltage (ACV) voltage between black and brown wires of J2 on Power Supply Card (This value will be 220VAC / 110VAC /24VAC depending on the customer requirement). If the appropriate required voltage is not measured then check the Molex connector between fuse plate and transformer.
- c. If the required voltage is measured but display continues to show the same error message then, replace the Power Supply Card. But if the requisite voltage is not measured then, the fault could be with transformer. Replace with new transformer and check again.

VI. DISPLAY- “Control supply fail”

TROUBLESHOOTING:

- a. Check whether Fuse-F3 is blown; If yes, replace with good fuse of 150mA, 250V rating.
- b. With the help of multimeter measure the Control Supply Voltage (AC voltage between Orange and Black wires of J2 on Power Supply card), which is to be 220VAC/110VAC as per the customer requirement. If voltage is still not coming then, check the Molex connector between fuse plate and transformer.
- c. If the requisite voltage is measured; but display continue to show the same error message then replace the Power Supply Card. But if the requisite voltage is not measured then, the fault could be with transformer. Replace with new transformer and check again.

VII. DISPLAY- “Jammed Valve”

TROUBLESHOOTING:

- a. The Jammed valve condition has to be released manually.

VIII. Motor running in wrong direction

Whenever there is a replacement of Motor then there is a possibility of occurrence of this error i.e. the actuator will run in wrong direction for the respective command inputs (actuator runs in open direction for close command and vice versa). To troubleshoot this, interchange any 2 wires of the motor when the Motor is replaced.

- IX. In case if Remote-Local mode selection option from REMOTE is not happening (optional feature); check for the wiring at the customer end according to the WD.
- X. In case of actuator running inadvertently (with ‘ESD’ message on LCD) either in OPEN or CLOSE direction depending on the software configuration, check if ESD is activated (wiring mistake) using the WD provided.
- XI. In case the actuator is not taking command in any particular direction check if INHIBIT feature is enabled (wiring mistake) using the WD provided.
- XII. In case the motor is not responding to the OPEN & CLOSE command and OPENING/CLOSING is indicated on LCD:
Check if J3 of Power Supply card is plugged properly. Check the requisite voltages (110/230V) at the contactor terminals (K, K1 & K, K2 –refer Fig. E below).
 - a) If the voltages are proper then, it could be the failure of the contactor; Replace the contactor.

- b) If the voltages are not proper, it means relay failure on the PS card. Replace the PS card.



Fig. E: Contactor

XIII. 4-20mA Signal Fail:

TROUBLESHOOT:

- a. Check if 4-20mA values in Diagnostic Mode are less than 30 or greater than 2000.
 - b. Under Remote-regulating duty mode we have to give 4-20mA DC Current from external DC source to the respective terminals (as per WD) named with ferrule "II+" and "II-".
 - c. Check the connectivity of J5 connector at the Interface Board and also verify the wiring with respect to WD and ensure that the 4- 20mA input is coming from DCS.
 - d. If the 4-20mA values in Diagnostic Mode is correct and a signal fail still occurs, then replace the IF card.
- XIV. Mode selected in Local option is not displaying on the LCD screen: This problem arises if "Remote Sel. Switch" option is enabled. To disable this option, enter into the Program Mode – General Settings

XVI. LCD Display is blank with back light ON:

Check whether all respective connectors are plugged properly and ensure that the shorting link is connected properly on J2, J3 & J19 of CPU card as shown below.

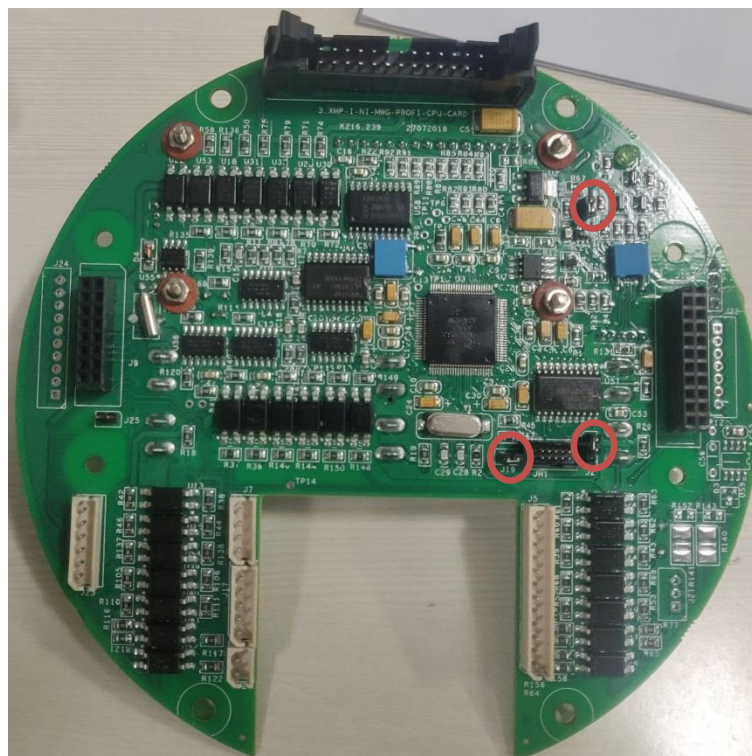

8. EPAC NAMEPLATE

Each actuator will have a nameplate associated with it which contains several important details. Please locate where the plate is present in your actuator. The information provided in the nameplates is delineated below. These are required to ensure our support after supply. There are several variations of nameplates available. Please match your actuator nameplate with the appropriate one below to obtain the required information. You are requested to furnish the below details of the name plate while ordering spare parts/after sales support.

Weather Proof Name Plates:

Variation 1:

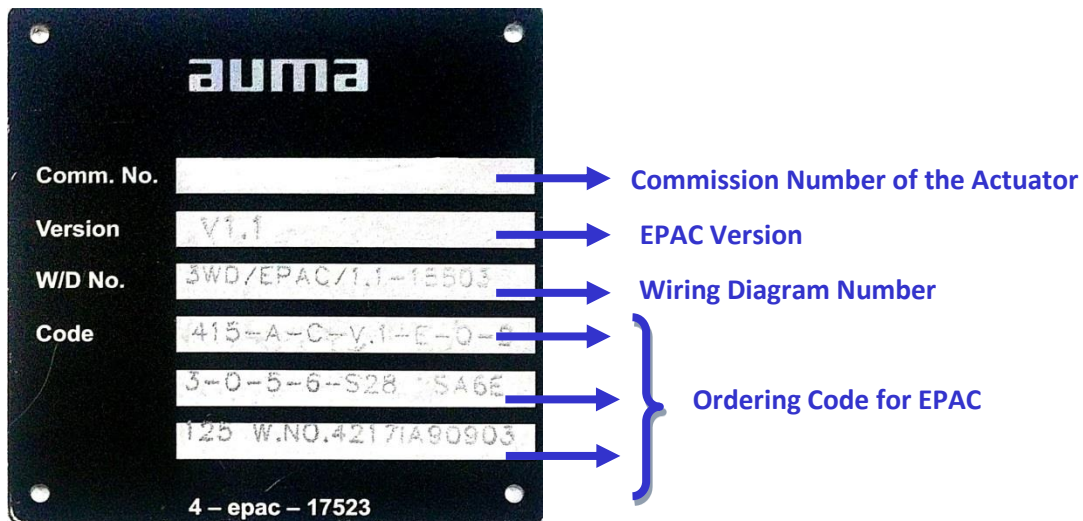

Variation 2:

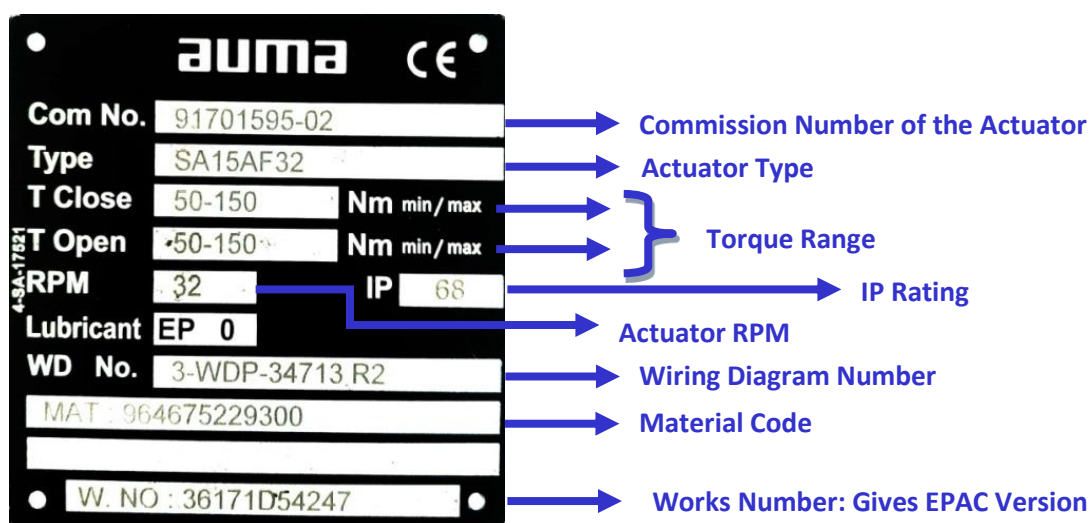

The Works Number mentioned in this name plate gives other details besides giving the EPAC Version. The actuator type gives the maximum torque, RPM of the actuator, weather

proof/explosion proof and on-off/regulating duty.

Explosion Proof Name Plates:

Actuator Nameplate: This plate contains the actuator specifications.

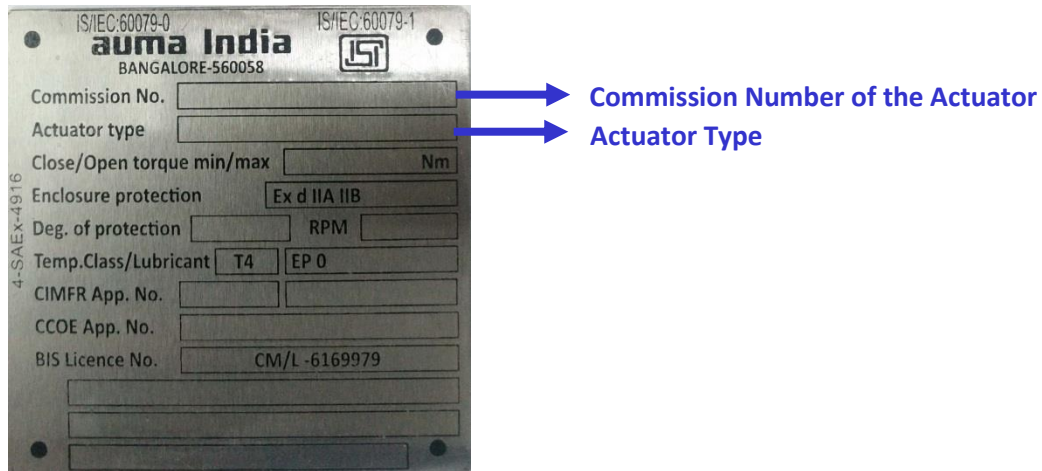

EPAC Nameplate : This gives the complete information of the EPAC version and Wiring diagram used.

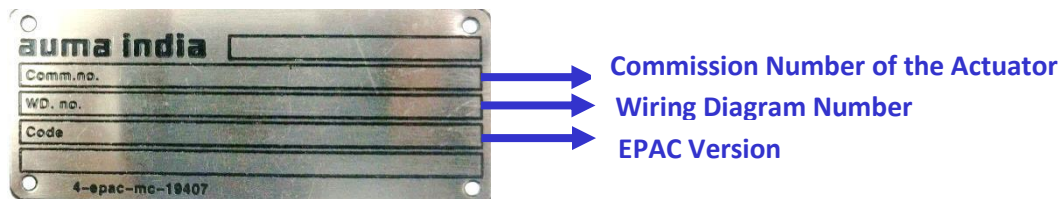

9. DISPOSAL AND RECYCLING

AUMA actuators have a long lifetime. However based on frequent usage and site conditions, one will have to replace them. As our actuators have a modular design structure, they may be easily disassembled, separated and sorted according to materials i.e.

- Electronic scrap
- Plastics
- Various metals
- Greases and Oils

The guidelines to be followed are:

- Please collect greases and oils during disassembly. As these substances are hazardous to the environment, please make sure not to release them into water.
- Ensure sound disposal or recycling process for each disassembled material.
- Ensure observation of the national regulations for waste disposal.

10. SERVICE

AUMA offers extensive services such as maintenance and inspection for actuators. The contact details are given below. For Spare parts related details, please refer to 3.XMP WITH DATALOGGING OEM SPARES LIST (This document will be available on Auma India Website – www.auma.co.in).

auma® india pvt ltd

Regd. Office & Works:

38A & 39-B, II Phase, Peenya Industrial Area Bangalore – 560058
Ph: 080-30412222/28394656
Fax: 080-28392809
Email: info@uma.co.in

Noida Branch:

#1310, Tower 'A', Corenthum Complex Sector -62, Noida -201309
Ph: 0120-3060522 – 26
Fax: 0120-3060523
Email: VeereshS@uma.co.in

Pune Branch:

#712,713, Bldg.No. 1, "Siddharth towers", Kothrud, Pune –411038
Ph: 020-25410465
Fax: 020-25443186
Email: NCPatil@umaindia.com

Chennai Branch:

Flat No-4, Eden Villa, 1st Floor, 10/21, West Main Road, Shenoy Nagar, Chennai-600030
Ph: 09884119795
Email: vramanan@umaindia.com

Residential Representatives

Kolkatta Branch:

Ph: 09883029170
Email: vsppatra@umaindia.com

Residential Representatives

Hyderabad Branch:

Ph: 09342694102
Email: MaheshKP@uma.co.in

DD/MN.035 01/2020