

# infaumation

'Getting connected to our customers through Infaumation window'

MARKETING  
ORDERS BAGGED

## AUMA India bags orders for supplying electric actuators for NTPC - MALWA 2 x 660 MW Shree Singaji Thermal Power Plant

AUMA India bags orders for 2 x 660 MW Shree Singaji Thermal power plant project being put up by NTPC @ Malwa for supplying electric actuators for the Boiler & Turbine package.



## AUMA India receives orders for electric actuators for NTPC - Gadawara 4 x 800 MW Ultra Super Critical Thermal Power Plant

AUMA India receives orders for supplying electric actuators for NTPC - Gadawara 4 x 800 MW Ultra Super-Critical Coal based Thermal Power Plant.

## AUMA India bags MSEDCL Grid order of TMC's solar power project for panel positioning

AUMA India bags MSEDCL Solar Grid Power Project of Thane Municipal Corporation (TMC) that has embarked on powering its offices across the nine wards with solar energy.



## AUMA India actuators to be a part of BWSSB water treatment projects - Cauvery Water Supply Scheme Stage IV Phase - II

AUMA India receives order for supplying actuators and gearboxes for the erection of single sluice gate (6 nos) each with 6 MT capacity of water treatment units at TK Halli & Tataguni, Harohalli respectively for BWSSB Bangalore.



## Dissemination and Awareness on E-waste management by KSPCB jointly with AUMA India

AUMA India has taken up the privilege in hosting the seminar on Feb 9<sup>th</sup> 2016 on the topic of e-waste management organised by the Karnataka State Pollution Control Board (KSPCB). Mr. Laxman, Hon'able Chairman of KSPCB inaugurated the event which was attended by 80 participants from various industries of Peenya Industrial Area. During his inaugural speech, he emphasised upon the urgency to bridge the gaps between e-waste generation and recycling, by improving channelisation mechanism for proper recycling. The event resulted in the successful outcome of creating awareness among the industrial stakeholders, to practice reuse, recycle and recover of e-waste, without damaging the environment. Also, a brief session was there on the case study discussion of Solar power generation & its benefits.



## National Safety Day Celebration @ AUMA India

National Safety Day 2016 programme was conducted by AUMA India and prizes were distributed for the employees who participated in Safety Quiz event. AUMA India periodically assesses & reviews the status on Safety, Health and Environment by using various techniques such as Order & Cleanliness and Safety Audits. This year AUMA India conducted safety campaign during the first week of March 2016 with both theoretical & practical sessions on new and useful information on industrial safety including the role of employees during emergency situations.



## AUMA India's Solar Power Plant: An Epitome of Energy Efficiency & Power Management system

AUMA India has become the first company in the whole of Peenya which comprises of more than 10,000 industries to export surplus power to BESCOM Grid with the self generation capacity for captive consumption of solar power.

With the total commissioned capacity of 375 kWp of solar power generation from the solar roof top project, AUMA India is the first industry in Peenya, the largest industrial area of South Asia to become an Energy Efficient Leader in achieving the goal of reducing dependency on fossil fuel based energy sources.

AUMA India serves as an epitome of energy efficiency and power management with the overall reduction of 442 tonnes of carbon emissions per year. Now, AUMA India's 50% of overall power requirement had been satisfied from clean energy generated by solar power plant following the model of "Self generation for Grid Connected (Net Metered) Captive consumption".



## AUMA India's Net-metering System with BESCOM Grid Export Facility

AUMA India has installed a net metering system to export the surplus power generated especially during weekly offs and holidays to BESCOM grid. As of March 2016, AUMA India has exported 24082 units in total to BESCOM since November 2015.

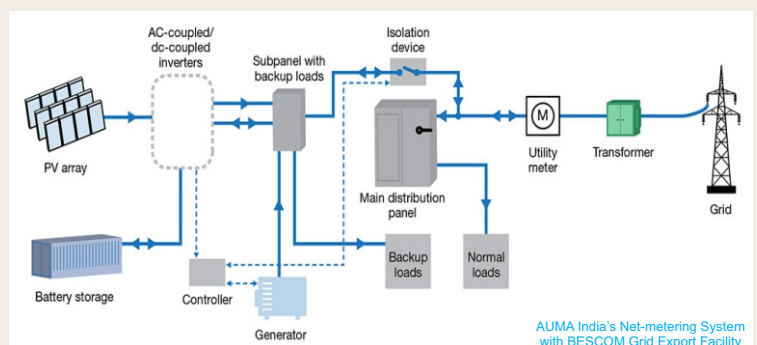

## Service & Commissioning Support activities carried out by AUMA India

AUMA India has been carrying out various Service & commissioning activities - R & M/ AMC support for the retrofit of actuators across various customer sites viz. IOCL Rangpo site at Sikkim, Oil India - Duliajan & Moran, BPCL - Kochi in the last quarter. Under Asset management - overhauling & maintenance, AUMA India offers the maintenance and inspection service at regular intervals, adapted and defined in accordance with the customized requirements.



Location: IOCL Rangpo site @ Sikkim

### Benefits/ Advantages of Renovation & Modernization (R & M) scheme offered by AUMA India

- Automation of manual valves including master station
- Implementation of modern automation concepts
- Experienced team for site study/evaluation to offer best automation solution
- Retrofitting/ Replacement of old actuators (any -make) with current actuators of AUMA India

### AUMA India In-house Customer Service Training Programme Calendar

TRAINING START DATE	TRAINING END DATE
21-04-2016	23-04-2016
07-07-2016	09-07-2016
20-10-2016	22-10-2016
04-01-2017	06-01-2017

For registration details, please contact Service@auma.co.in/ UmeshK@auma.co.in/ PrashanthS@auma.co.in

## 'AUMA India join hands with ISKCON in facilitating Akshaya Patra service'

AUMA India as a part of corporate Social Responsibility activity has provided two food distribution vans to ISKCON for 'Akshaya Patra' service that provides mid-day meals for the schools in and around Bangalore serving needy school children. So far, AUMA India has donated 9 food distribution vans to Ashaya Patra Foundation as a part of CSR activity towards the development of local community.



Akshaya Patra Food Distribution Van displaying AUMA India's name

## 'AUMA India empowers children through education support'

AUMA India has provided a significant contribution to support the activities of 'Shanti Bhavan Education Trust' which aims to alleviate poverty, promote environmental health and strengthen democratic institutions & values in developing countries.



Shanti Bhavan Education Trustees with AUMA Directors

## AUMA India Pvt. Ltd.

### Head Office & Works:

Plot No.: 38 A & 39 B, II Phase, Peenya Industrial Area, Bengaluru -560058.

### Contact:

Phone: 080-30412222  
Fax No: 080-28392809  
E-mail: info@auma.co.in

### Branch Offices:

NOIDA: 0120-3060522  
PUNE: 020-25410465  
CHENNAI: 044-45524447

### Residential Representatives:

KOLKATA: +91 9937431333  
HYDERABAD: +91 9342694012  
VADODARA: +91 9974645180

### Newsletter Editor



News Bulletin Icons

### Links



Brochure  
Catalogue

Access AUMA India Website

<http://www1.auma.com/cms/AUMA/india> for the below links



LINKS/TAB	DESCRIPTION	
SERVICE/SUPPORT	Service Warranty - Free 18 Months Additional Warranty Registration	
QUICK LINKS	Newsletter	3D Solid Models
	All Documents	Quick Start Guide
YOUTUBE LINKS	In-house Manufacturing & R & D Facility videos	



The Leader in the field of Electric Actuation Products

# auma®

Solutions for a world in motion