

# Dimension Data sheet for Multi-turn Bevel Gearboxes

## BEVEL GEARBOX DIMENSIONAL DATA

GK 40.1

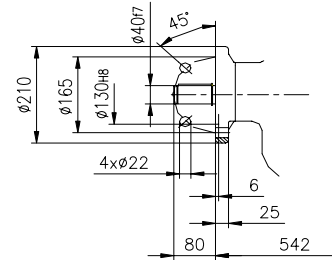
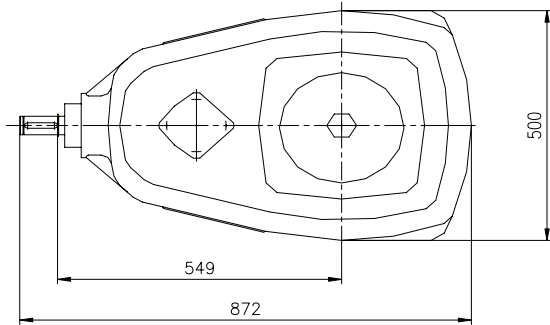

Mounting flange for multi-turn actuator  
F16- ISO 5210  
G3-DIN 3210

Version for manual or remote operation

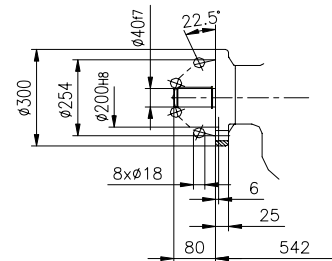
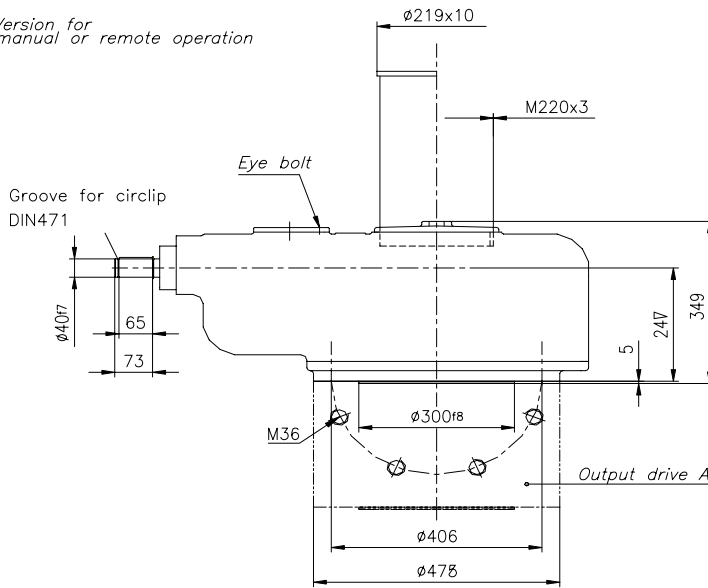

Mounting flange for multi-turn actuator  
F25- ISO 5210

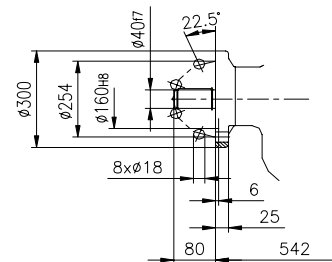

Mounting flange for multi-turn actuator  
G4- DIN 3210

### 'A' Type Output drive details F40 - ISO 5210

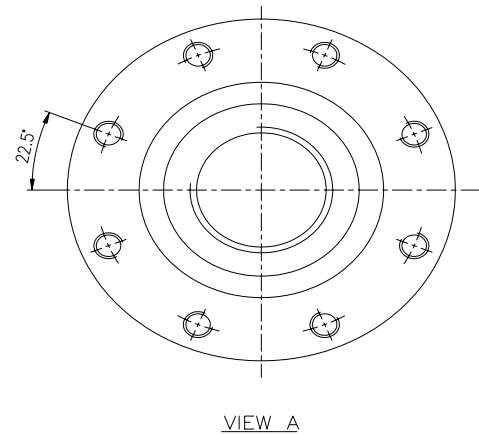
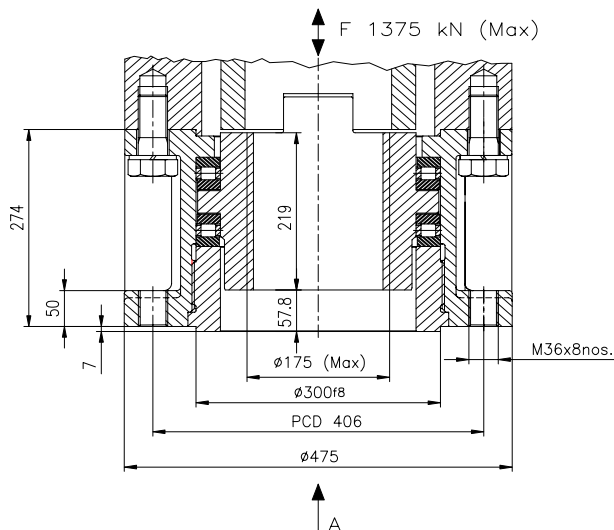

VIEW A

Weight :- 200kg

Note:- Other types of output drives shall be offered on request.

We reserve the right to alter data according to improvements made. Previous data sheets become invalid with the issue of this data sheet.