

Your expert partner for electric actuators

PORTRAIT | MARKETS | PRODUCTS



AUMA automate valves

And this for the last 50 years.

The two-man partnership has evolved into a global corporation, implementing their innovative products for industrial valve automation all around the globe.

You are invited to join us on our expedition.

Get to know AUMA and learn who we are, what we do – and how we can serve you.



Matthias Dinse
Commercial Managing Director



Henrik Newerla
Technical Managing Director



Portrait

Your expert partner for electric actuators
Customised actuators for all valve types
Facilities
Global network
Production
Assembly
Quality assurance
Research & development
Corporate social responsibility

Page 4



Markets

Water
Energy
Oil & Gas
Industrial and special solutions

Page 24

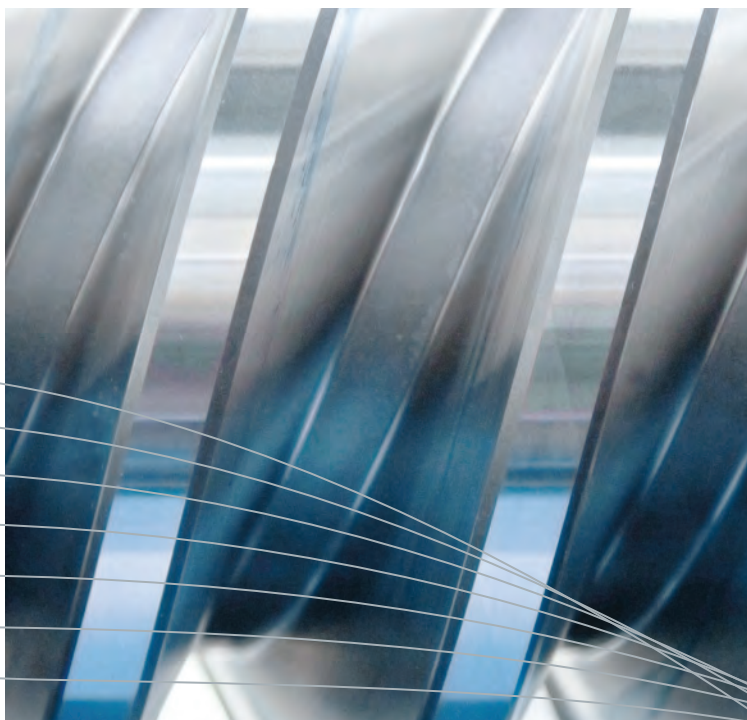

Products

Multi-turn actuators
Part-turn actuators
Combinations
Services
Qualifications and certificates

Page 44

PORTRAIT

Company insights



Armaturen- Und Maschinen- Antriebe



AUMA, the leading manufacturer of electric actuators for automating industrial valves. We are a medium-sized owner-managed enterprise combining a value-oriented culture with flexibility and reliability.

1964–2014

50 YEARS OF INNOVATION IN ACTUATORS

Since the foundation of the company in 1964 by Werner Riester and Rudolf Dinse, we have focused our complete engineering excellence on developing, manufacturing and distributing electric actuators. With our pioneering spirit and the clear feeling for market requirements, we have grown to a global technological leader. With our customers, our products are renowned for their long product life, reliability and highest precision.

Most of the product components are manufactured in our own, modern manufacturing plants. This is how we can guarantee top quality of AUMA actuators.

1964

Established at Ostfildern/Nellingen nearby Stuttgart, Germany

1967

First multi-turn actuator type range SA 4 – SA 70

1971

Muellheim is designated as AUMA's new headquarters

1974

First subsidiary AUMA Benelux

1976

Foundation of AUMA USA; multi-turn actuators SA 6 – SA 100



YOUR EXPERT PARTNER FOR ELECTRIC ACTUATORS

WORLDWIDE SALES AND SERVICE

'All business is local' – this conviction led us to found our first subsidiary, AUMA Benelux, as early as 1974. Thanks to our cosmopolitan sales and service network, our customers trust us to find competent local support in more than 70 countries all around the globe.

SUSTAINABLE GROWTH

AUMA have grown to a successful global player, giving work to more than 2,300 people worldwide. Still today, we are an owner-managed private enterprise. We are committed as a reliable partner for our customers underpinned by our sound financial background and long-term growth strategies.

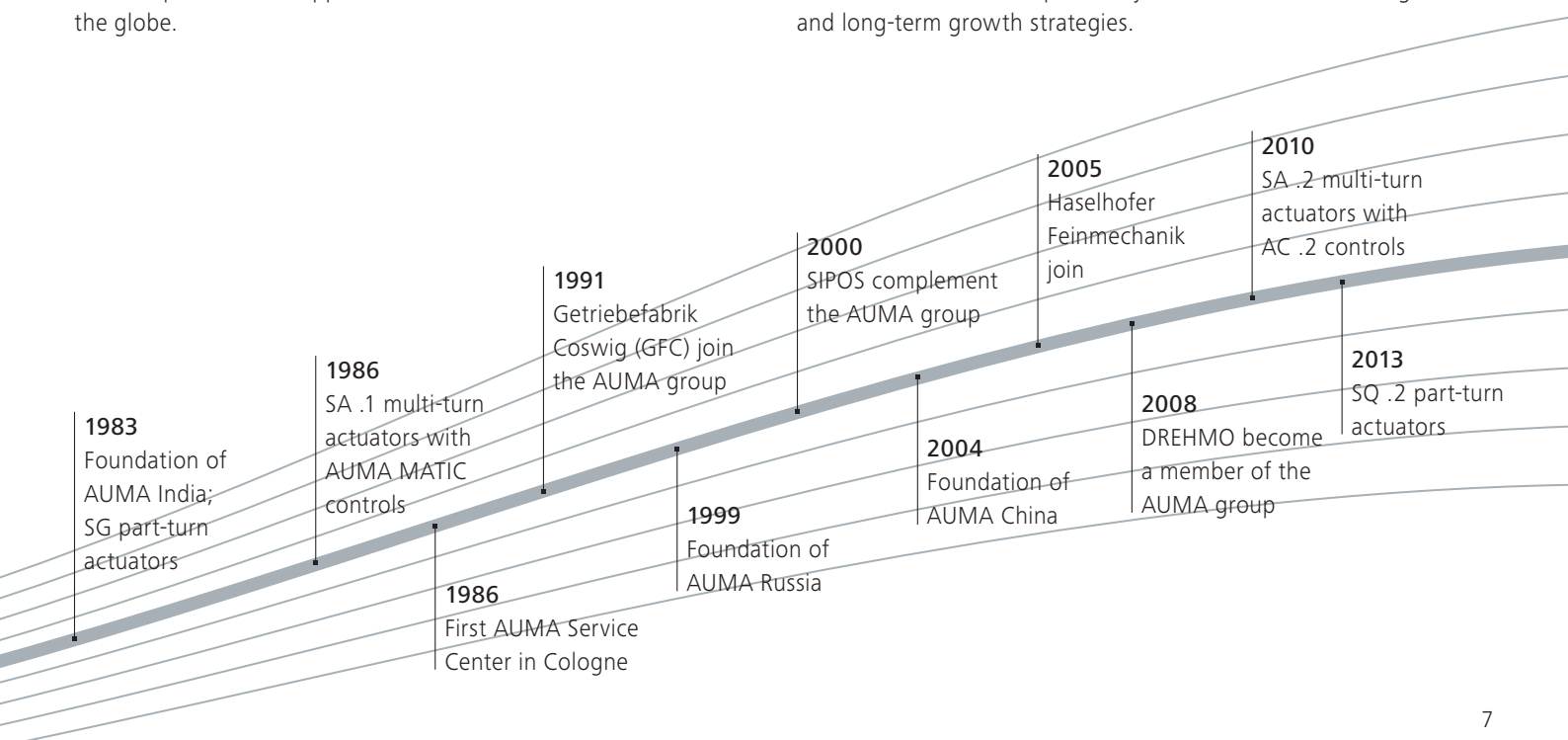

AUMA actuators work reliably all around the globe in water supply and wastewater treatment, in power plants, pipelines, refineries, and industrial plants of any kind – managing the flow of liquids or gases, powders or granulates.

AUTOMATION OF ALL VALVE TYPES

Our actuators are tailored to customer-specific needs. Thanks to our comprehensive product portfolio including high performance multi-turn, part-turn, linear, and lever actuators, we offer automation solutions for any type of valve – from two-inch ball valves to diverter dampers metres high.

HIGHEST RELIABILITY

AUMA actuators comply with international standards and are designed to excel in utmost reliability and long product working lives – limiting maintenance requirements to an absolute minimum. AUMA actuators guarantee reliable and safe service even in most hostile environmental conditions.

EASY INTEGRATION

More than just fulfilling the purpose as mechanical interface to the valve, our products are the crucial interface to control systems. Modern AUMA actuator controls cater for safe communication with commonly used site control systems. Flexible device positioning and configuration including comprehensive accessories satisfy any variety of installation specifications.

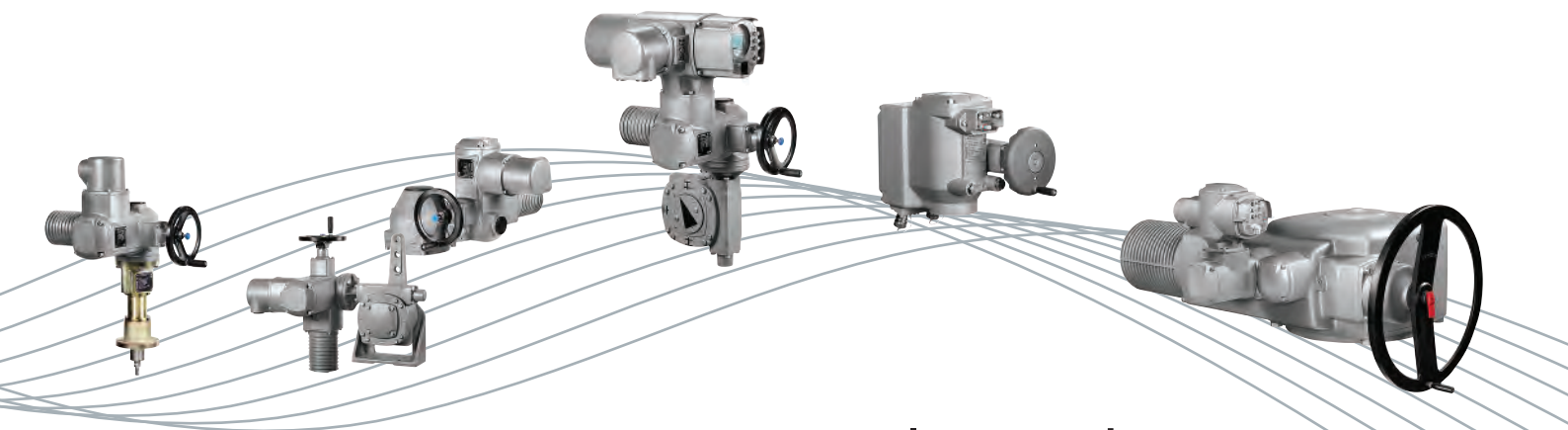

Tailored solutions



CUSTOMISED ACTUATORS FOR ALL VALVE TYPES



Muellheim headquarters, at the foot of the Black Forest is the heart of the AUMA group. The tripoint where the borders of Germany, France, and Switzerland meet is the ideal spot due to the highly developed infrastructure and perfectly qualified available workforce. Traditional values like reliability, quality, and sustainability are deeply rooted.

High tech with tradition



FACILITIES IN GERMANY



IN YOUR VICINITY THROUGHOUT GERMANY

With three production sites, three Service Centers, and nine regional sales offices, we at AUMA are in your direct vicinity throughout Germany. Across all sites, we are committed to create long-term workplaces and a modern working environment.

Steadily increasing order entries required extension of our manufacturing capacities and successively led to refurbishment and replacement of buildings and production plants. The AUMA plants in Muellheim, Ostfildern, and Coswig give home to actuator, gearbox, and actuator controls production deploying modern manufacturing systems and implementing latest process technologies.

AUMA HEADQUARTERS, PLANT MUELLHEIM

- > 700 employees
- > 18,000 m² manufacturing surface
- > Production of SA multi-turn actuators, AM and AC actuator controls, GK and GST multi-turn gearboxes

AUMA PLANT OSTFILDERN

- > 100 employees
- > 6,000 m² manufacturing surface
- > Production of SQ, SG, SGC, SGM part-turn actuators, SVC, SVM multi-turn actuators

AUMA PLANT GFC COSWIG

- > 200 employees
- > 6,000 m² manufacturing surface
- > Production of GS part-turn gearboxes



Headquarters, plant Muellheim

From the very beginning to the present, we have been striving to support our customers all around the globe, assist them with competent excellence and offer comprehensive local and on-site service.

Worldwide in your vicinity

GLOBAL NETWORK



ADVICE, SALES, AND SERVICE

As a globally acting enterprise, AUMA possess a comprehensive sales and service network. Our local engineers are can be found in all parts of the globe and they are deeply committed in advising and supporting you in your national language relating to all issues about AUMA actuators. Experienced AUMA service engineers ensure worldwide support with installation, operation, and maintenance of our products.

LOCAL MANUFACTURING

Production sites in Germany, the USA, India, and China guarantee short transport and delivery times. We manufacture according to identical exacting AUMA quality standards throughout all our factories.



AUMA WORLDWIDE

- > More than 20 subsidiaries
- > More than 50 representative offices
- > Production sites in Germany, Production in USA, India, and China to satisfy local needs

EUROPE

Belgium*
Bulgaria
Denmark
Germany
Estonia
Finland*
France*
Greece
United Kingdom*
Ireland
Iceland
Italy*
Croatia
Malta
The Netherlands*

Norway
Austria*
Poland*
Portugal
Romania
Russian Federation*
Sweden*
Switzerland*
Slovakia
Spain
Czech Republic*
Turkey*
Ukraine
Hungary
Belarus

AMERICA

Argentina
Brazil*
Chile
Ecuador
Canada
Colombia
Cuba
Mexico
Peru
Puerto Rico
Trinidad Tobago
USA*
Venezuela

AFRICA

Egypt
Algeria
Morocco
Nigeria
South Africa*
Tunisia

AUSTRALIA

Australia

ASIA

Bahrain*
China*
Hong Kong
India*

Indonesia
Iran
Iraq
Japan*
Jordan
Kazakhstan
Qatar
Korea
Kuwait
Lebanon
Malaysia
Oman
Pakistan
Philippines
Saudi Arabia
Singapore*

South Korea
Syria
Taiwan
Thailand
Uzbekistan
United Arab Emirates
Vietnam

* AUMA subsidiary

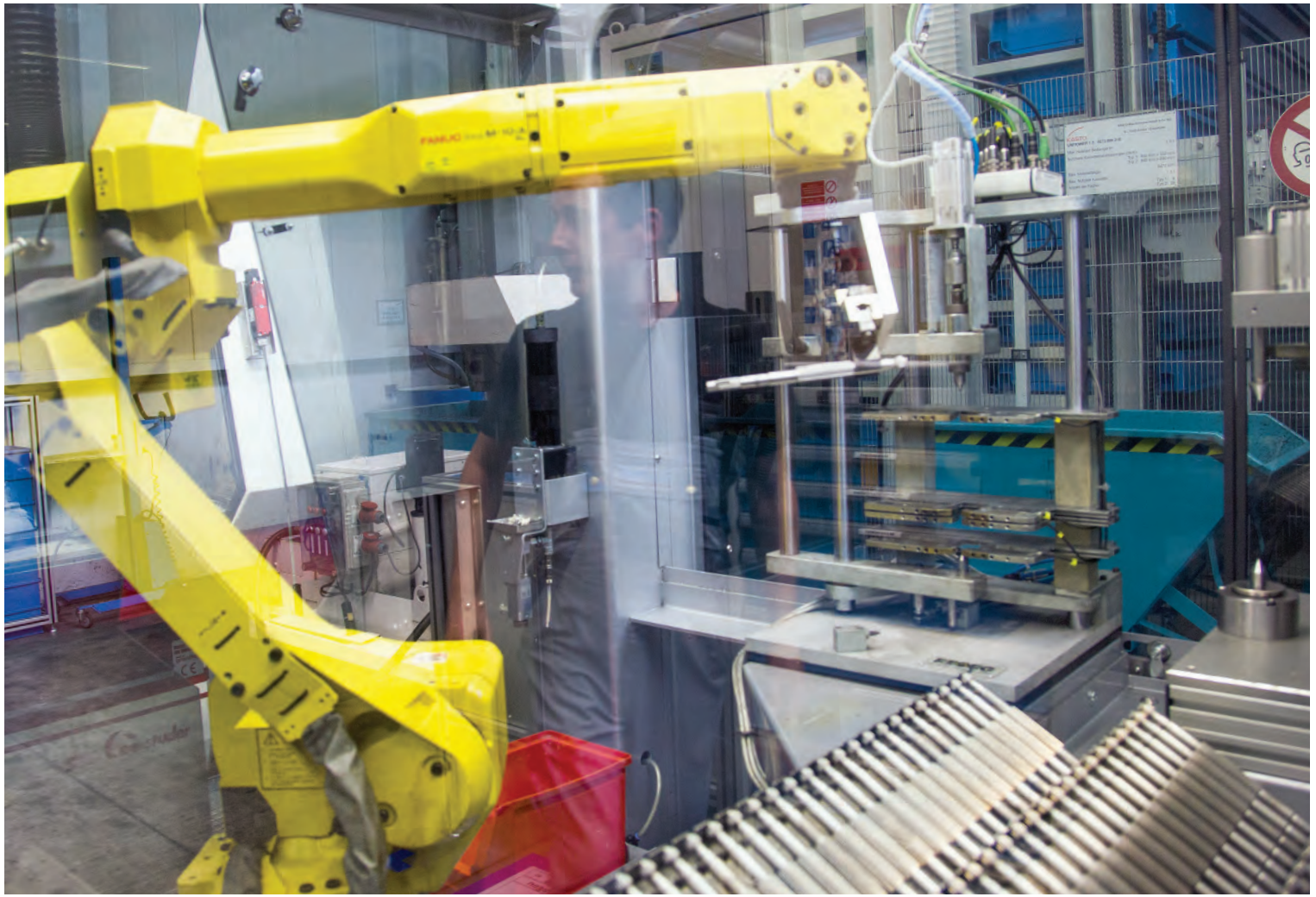

PRODUCTION

State-of-the-art production facilities

Manufacturing in our own plants is a crucial factor in favour of ensuring the constant top quality of AUMA products. We can immediately react to and comply with changing requirements while ensuring adherence to deadlines.

ORDER-RELATED PRODUCTION

AUMA products are by no means considered as mass products in spite of the challenging total number of more than 180,000 actuators per year. We are committed to manufacture each actuator complying to orders whilst implementing the specific customer needs. Consequently, we are in a position to offer a diversity of variants to our customers beyond our competition.

SINGLE SOURCE SUPPLY

Design, process planning, machining, surface treatment, assembly, logistics, quality management – we at AUMA manage and control the complete production chain. Our components are manufactured on a production surface of more than 60,000 m² worldwide and we guarantee outstanding quality and precise processing at each stage of the process.



LATEST PROCESS TECHNOLOGY

AUMA's ongoing investments into the most modern machine and process technology are the driving factor for continuously increasing productivity. Latest generation machining centres ensure efficient and dimensionally accurate manufacture of housing and gearing parts.

POWDER COATING FOR TOP GRADE CORROSION PROTECTION

AUMA's unique two-layer powder coating for their products is spearheading the market standards for corrosion protection. At the same time, it reduces environmental impacts thanks to considerable pollution reduction. Powder coating individual parts promotes outstanding corrosion resistance with particular adequacy for the offshore segment.



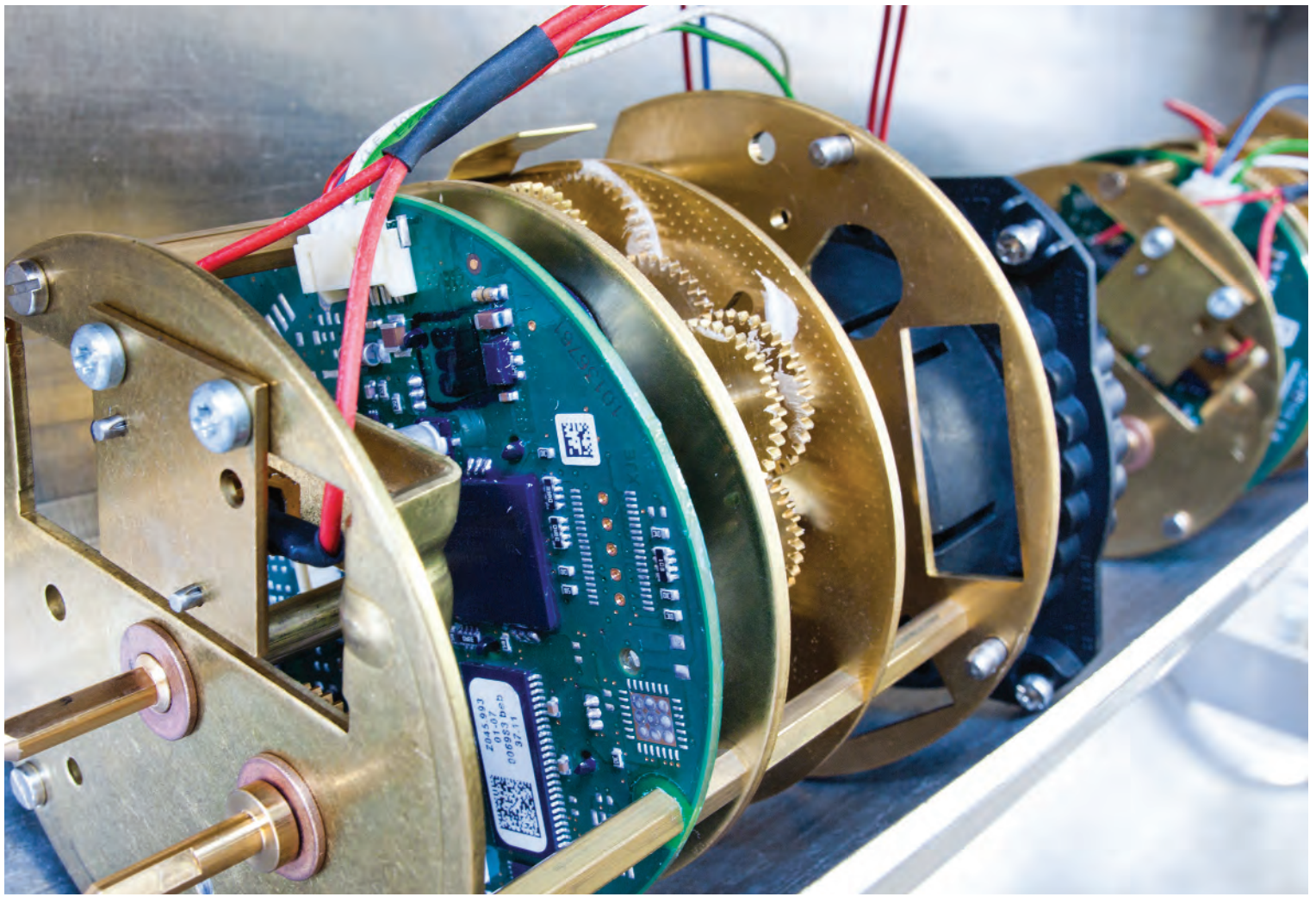

ASSEMBLY

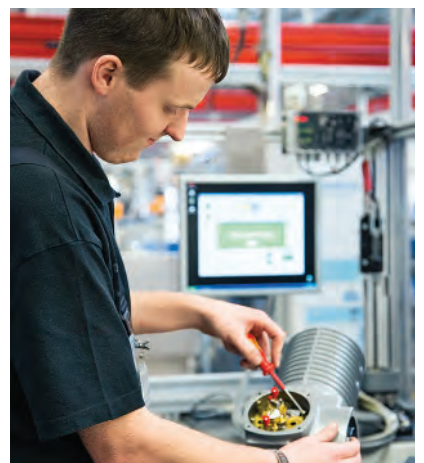

The comprehensive range of variants of our products continuously challenges the sophisticated demands relating to logistics, stock keeping, and assembly. Optimised processes and trained staff ensure that all working processes are precisely executed as ordered by our customers.

CONTINUAL PROCESS OPTIMISATION

Ongoing analysis, structuring, and optimisation across the process landscape allow us to provide our customers with superior quality at competitive prices. Proven processes are introduced and implemented throughout the AUMA group.

EFFICIENT ASSEMBLY

Our trained staff in assembly know every flick of the wrist by heart. Utmost care is taken to assemble complex sub-assemblies such as control units, actuators, and actuator controls. Ergonomically designed workplaces are created and ensure minimum delivery distance, allowing for efficient assembly even when dealing with complex sub-assemblies.

ADHERENCE TO DEADLINES

Delivery of large numbers of units day by day require that material is made available in sufficient quantity at the right time in the right place. Our needs-oriented logistics ensure maximum availability of parts resulting in shorter delivery times.

Diligence in every detail



Reliable quality

AUMA actuators have acquired an excellent reputation amongst our customers, in particular relating to reliability and quality. This fills us with pride. And with determined endeavour, we shall stay on this track of success.

CONTINUOUS CONTROL

Quality assurance accompanies the complete production process, from goods receipt to final product dispatch. Checks of dimensional accuracy, for example, performed at the crucial stages of the processes during production establish that only complying components are further processed.

100 PERCENT TESTING

Comprehensive final inspection tests are performed for all actuators and actuator controls prior to leaving our factories. Test benches specifically developed and designed by AUMA support functional testing, and this often in the presence of our customers. At this stage, actuator limit and torque switching is calibrated.

Each individual housing part of explosion-proof actuators and actuator controls are subjected to an overpressure test. Explosion-proof joints are 100 % tested for accurate dimensions and perfect surfaces.

QUALITY ASSURANCE



INDEPENDENT CERTIFICATIONS

The high AUMA quality standard is confirmed in regular intervals by independent test authorities as basis for certification according to ISO 9001:2008 as well as ISO 14001:2004 valid for the overall AUMA group. We manufacture according to uniform quality standards throughout all our factories.

COMPREHENSIVE DOCUMENTATION

Records and inspection certificates are used to document all processes during manufacture and final inspection for traceability of measurements and results.

Inspection certificates, records and further certifications are available with AUMA on request or for download from the AUMA website.

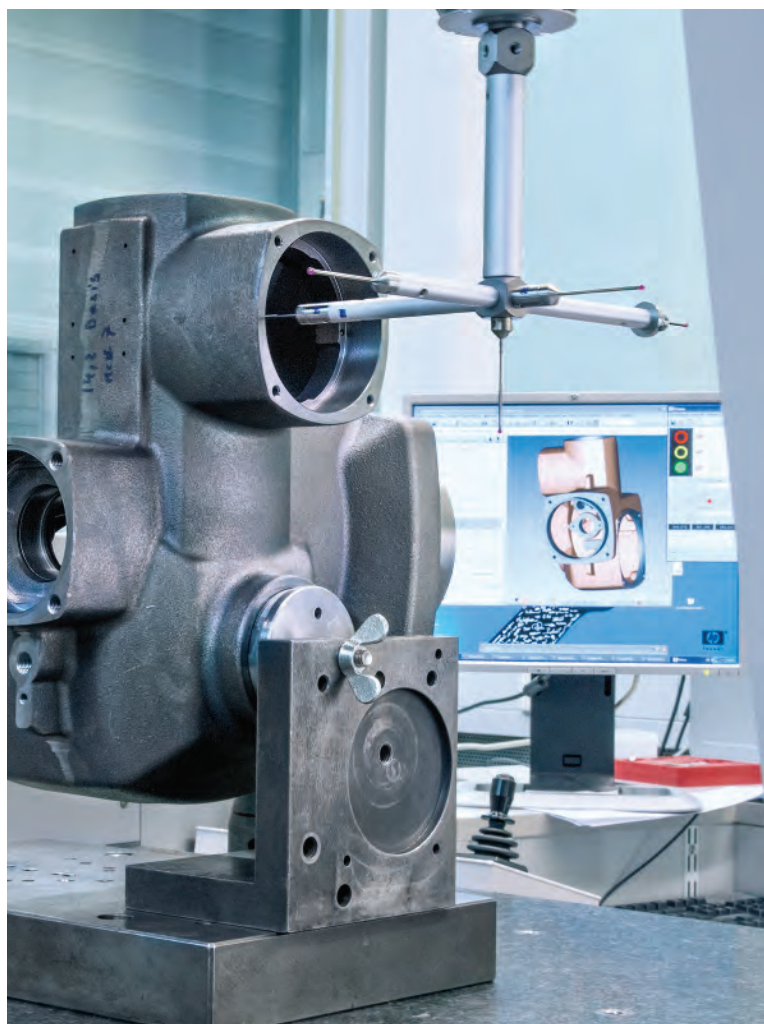

Commitment to Innovation

Demands on electric actuators are increasingly challenging; new technological facilities change the environment of process engineering. Our specialised development teams continuously work on enhancing and upgrading our products. Their innovative solutions spearhead market standards in fields like sensor technology, asset management, fieldbus technology, Wireless, SIL, and explosion protection.

EXPERTS IN ALL SEGMENTS

AUMA management took the company from its specialisation in mechanics to a spearheading position in technology: expert teams work on the development of mechanics, electronics and software. On the basis of proven processes, our experts work on optimising existing products and product enhancement including new developments of complete type ranges. Operation and test software for our actuators are in-house developments in compliance with the latest technologies.

MODULAR DESIGN FOR THE FUTURE

AUMA products rely on the modular concept. We have developed modular components which match perfectly with each other for ease of construction and on site assembly. Short distance between development and production facilitate swift implementation. The result is a well thought-through product portfolio, easy to enhance and expand, taking into consideration future customer needs.

RESEARCH & DEVELOPMENT

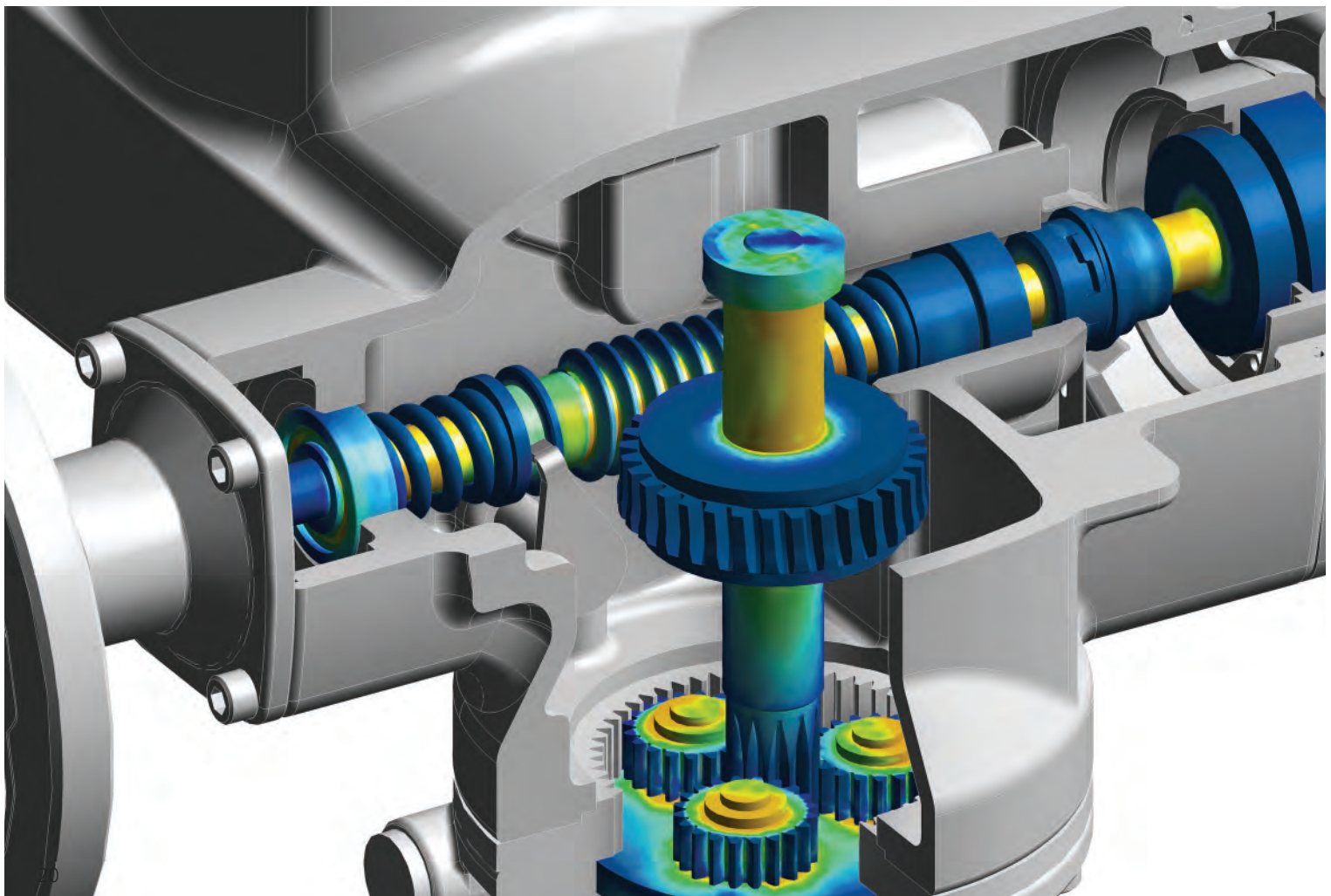

TESTING IN HARSH AND HOSTILE CONDITIONS

New housings, new electronics, new motors, new materials – prior to launching new products on the market, they are subjected to extremely harsh and hostile conditions at the AUMA test laboratories. They must prove their technical capabilities in climatic chambers, salt spray test chambers, or vibration simulations. Approval is assigned after successful achievement of results.

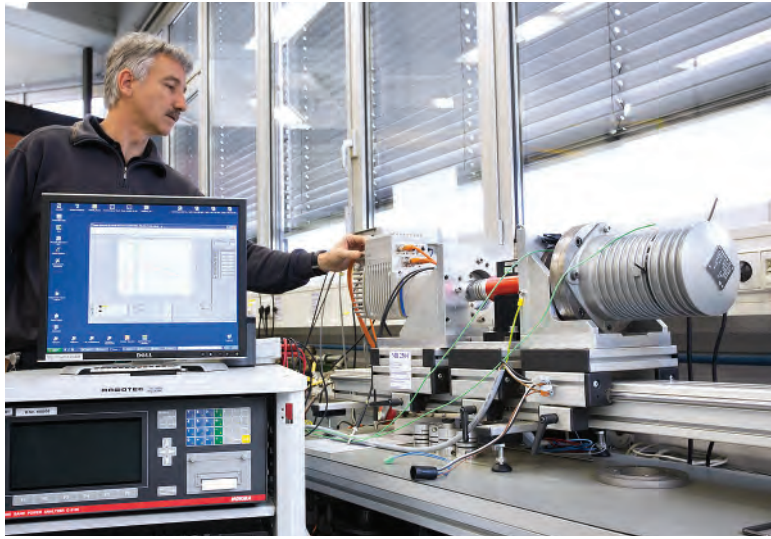

RELIABLE PRODUCTS

Product life of all components is reviewed in automated lifetime tests where switching cycles quickly follow one after the other. Technical specifications like temperature and vibration resistance, maximum torque or shortest operating time are reliably assessed in standardised test series. To make sure that AUMA products will keep their promise also in the future.



Achieving the goal together

As a global enterprise, we are aware of our responsibilities towards society. We are highly committed to fostering our personal relationships, to implement production methods minimising environmental impacts, and create fair opportunities for all stakeholders.

CORPORATE SOCIAL RESPONSIBILITY



MANAGING RESOURCES

Not only our products contribute considerably to efficient use and management of natural resources in many parts of the world. For us, ecological aspects in every day work are very important. We actively increase awareness among our staff, reduce waste, and improve the energy efficiency of our buildings – we tackle this crucial issue from many angles.

As early as product development, we at AUMA avoid hazardous substances: With electronic components, for example, we renounce to toxic agents like lead.

In production, we managed to halve solvent consumption by introducing powder coating, refraining from wet painting. Integrated waste water processing reduces fresh water consumption. Process heat generated by compressed air, for example, is recycled and reused.

OFFERING CHANCES AND OPPORTUNITIES

'Think globally, act locally' – this is the overall AUMA motto for donations of money and goods at local subsidiary level to support social institutions. Support is given to charity organisations but also to local sports clubs, schools and other facilities in need. As an example, AUMA actively contribute to the building of schools in Bangladesh, foster training and educational projects in India and support the drinking water supply in China.



RESPECTING VALUES

We focus on long-term and reliable relationships with our partners and with our staff. The AUMA culture values mutual appreciation and respect, nurturing the awareness that we strive for the same goal: Rendering optimum service and advice to our customers by awarding top priority to quality – with both our products and services.

DEVELOPING IDEAS

The road to success is spearheaded by our experienced staff who are strongly committed, day after day, in enhancing the quality of AUMA solutions. Our focal issue: Providing stable infrastructure and safe workplaces with fast decision-making processes, awarding space for responsibility, creativity, and innovation.

We have established a continual improvement programme encouraging all members of staff to submit suggestions and implement ideas.

Sports and social events create networks and nurture cooperation beyond departments and across various sites.

CREATING PERSPECTIVES

Individual training and educational programmes are implemented to support and enhance expert and personal competence of our staff. Besides our large variety of internal training and educational programmes, we encourage our staff to participate in external training schemes and give further support in implementing professional goals.

We are highly committed and proud to develop professional perspectives for young people. AUMA offer many corporate apprenticeships and educational schemes in administration and production. Trainee programmes are open to graduate students in gaining state-of-the-art knowledge in research and technology linked to practical and professional experience within the company.

MARKETS

Water
Energy
Oil & Gas
Industry

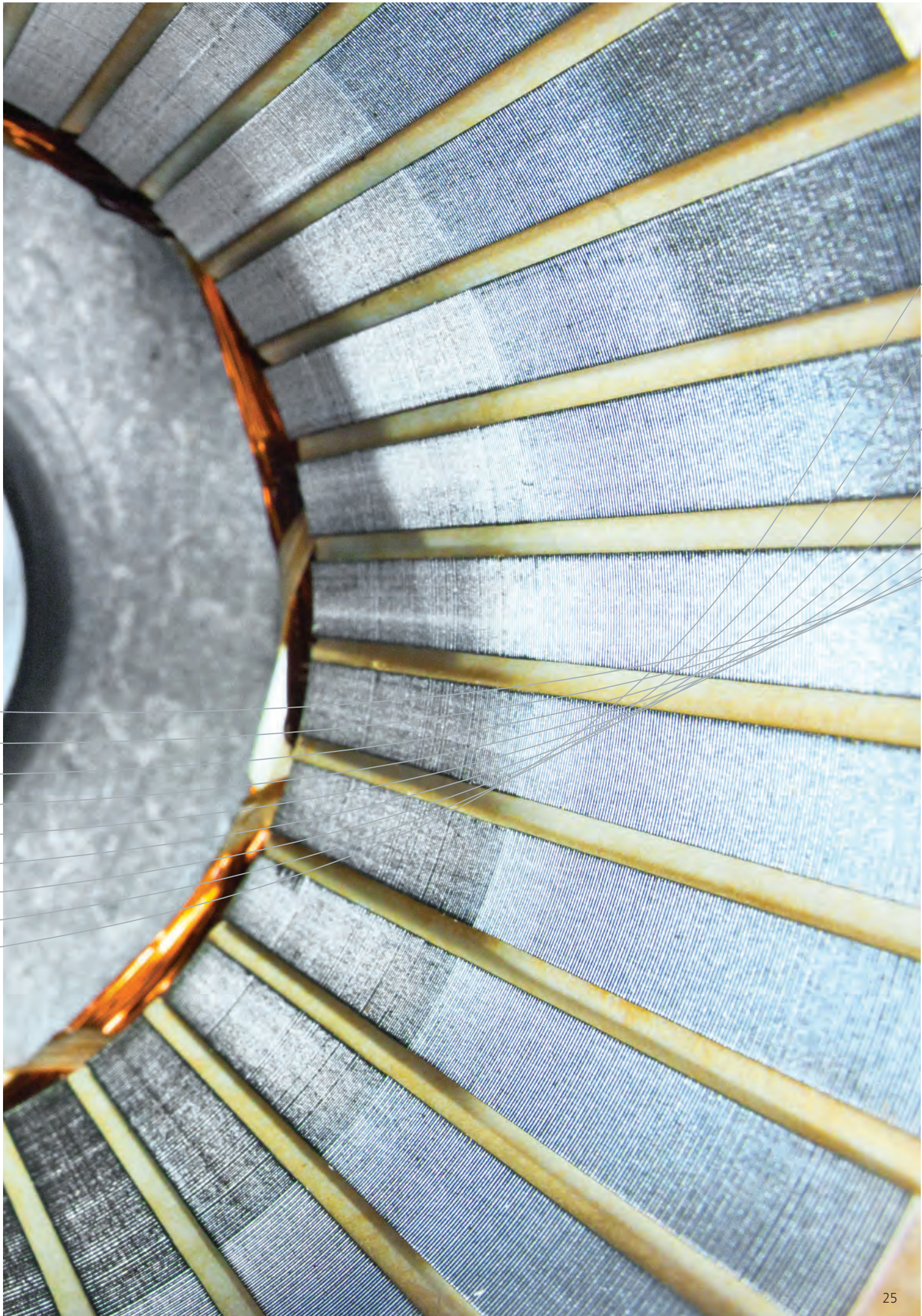

WATER

From potable water production and distribution, sewage treatment to steel constructions for water systems, AUMA actuators automate valves of any size and design.



ENERGY

AUMA actuators are relied upon for controlling water and steam flows in pipelines throughout power plants of all types. Offering a uniform interface for all automated valves, they are specifically adapted to power plant control stations.



SOLUTIONS FOR ALL MARKETS

Our customers at focus

OIL & GAS

International certification in explosion protection, high SIL capability, and perfect reliability in particularly harsh and arduous climatic conditions – AUMA actuators meet the crucial requirements of the oil & gas industry.

INDUSTRY

Thanks to the modular product design, AUMA actuators deliver convincing solutions and undisputable answers to plant specifications in industrial applications.

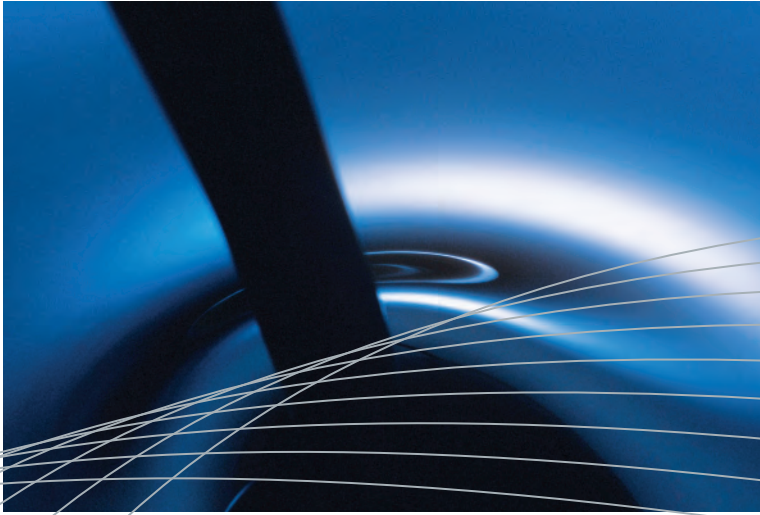

Commitment to customer needs is our driving force. As an independent manufacturer, we have pride in our long-term and successful cooperation with our customers in the valve industry, plant engineering, and process plant operation. We at AUMA offer established actuator solutions for the markets of water, energy, oil & gas, and industry.

RELIABLE PARTNERSHIP

We cooperate at all levels with our international partners and provide committed support at all phases of project management. Tasks and mission of the actuators are identified and determined during the ongoing dialogue with our customers.

Our global orientation allows for detailed local support by experienced AUMA sales engineers when selecting your ideal actuation solution. Our comprehensive service portfolio will accompany and assist you throughout the total lifetime of our products.

LONG-TERM SECURITY OF INVESTMENT

International production certifications and customer approvals confirm the excellent quality of AUMA actuators. Our actuators are designed for long product life whilst withstanding harshest environments. Their mission consists in delivering reliable and safe performance over many years or even decades.

Our modular products are compatible across all product generations. Of course we guarantee the availability of spare parts for ten years after discontinuation of a product.

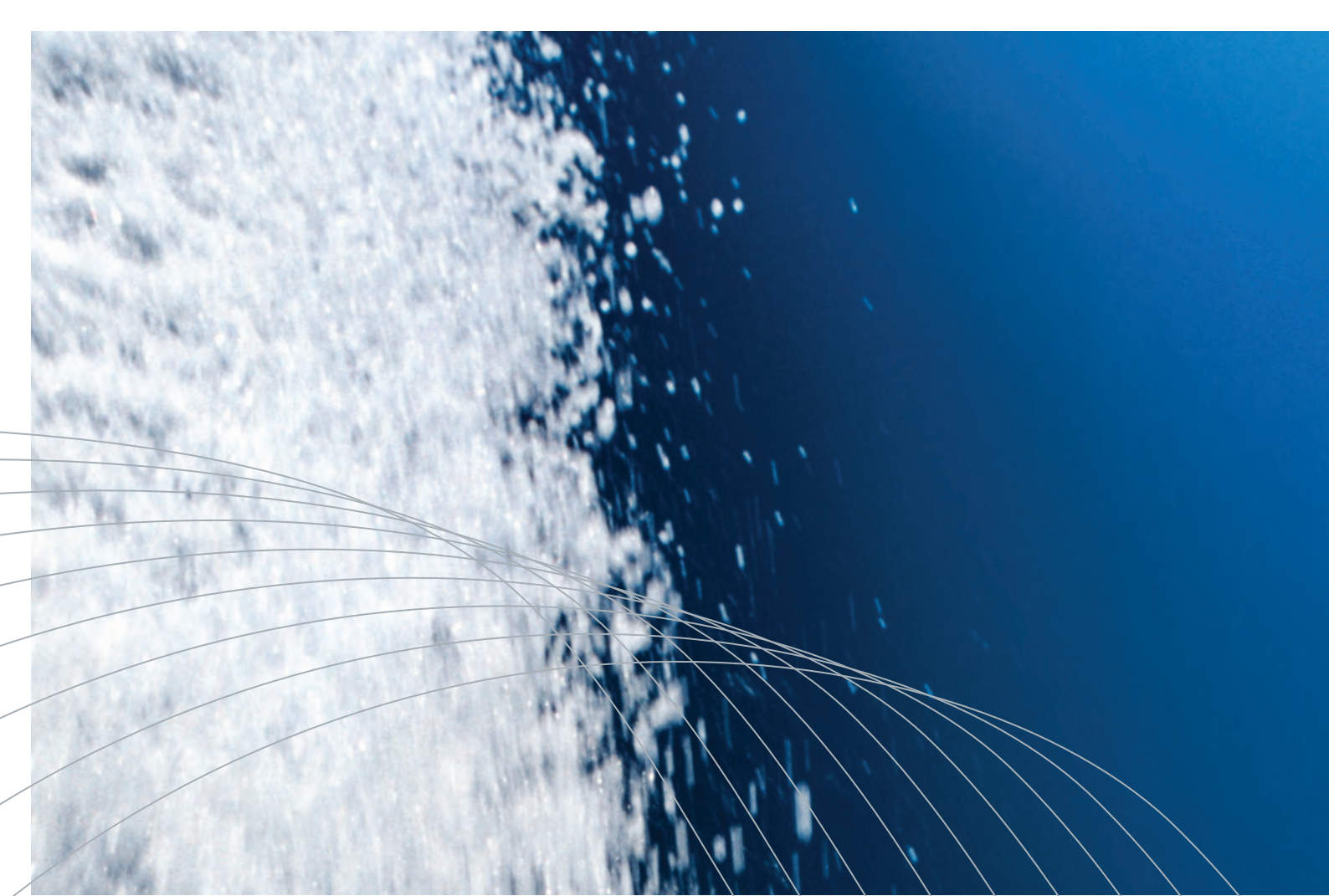

WATER

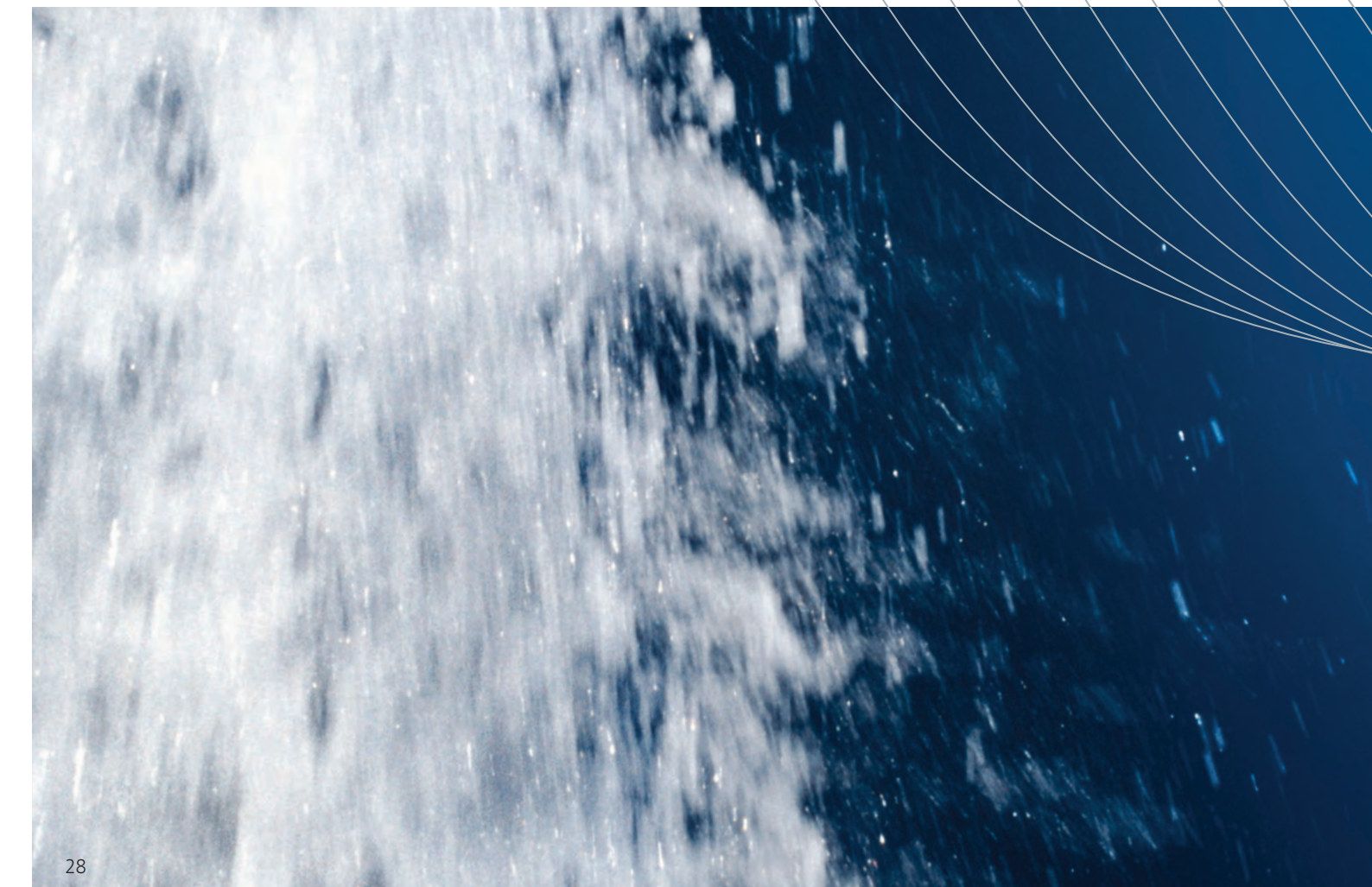



AUMA solutions
for the
water industry



Wealthy expertise of half a century

Clean water is the basis of all life. Potable water production and distribution, sewage treatment and disposal are core tasks of modern water management. Electric AUMA actuators warrant for dependable and reliable valve automation.

IN THE BEGINNING WAS THE WATER

AUMA actuators earned themselves an excellent reputation by meeting the special challenges and finding the perfect solutions in the water industry. Today, the AUMA brand is considered as synonym for long service life and ruggedness. For several decades, AUMA actuators have been providing reliable and efficient service all around the world whilst requiring next to no maintenance.



WATER



DESIGNED TO FIT ANY SIZE

From individual actuators for municipal sewage treatment plants to major projects combining several hundreds of units, from the small butterfly valves and ball valves to weirs metres high – AUMA solutions are trusted for all customer demands.

Our modular products are easy to retrofit in an existing installation when upgrading with modern actuation and control technology.

EASY INTEGRATION

Whether integration in established PLC control concepts or latest fieldbus technology is challenged – AUMA actuators guarantee empathic adaptability into any control system design.



- > SEWAGE TREATMENT PLANTS
- > WATER TREATMENT PLANTS
- > DRINKING WATER DISTRIBUTION
- > SEWAGE DISPOSAL
- > SEAWATER DESALINATION
- > STEEL CONSTRUCTIONS FOR WATER SYSTEMS
(SLUICE GATES, WEIRS, DAMS)



WATER
accounts for 30 %
of total turnover

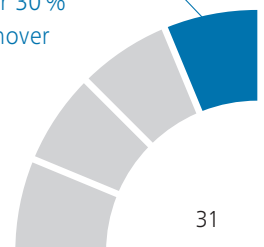



ENERGY





AUMA solutions
for the
power plant industry

Seamless integration

From conventional to regenerative power plants, sophisticated applications challenge mastering complex processes in harshest environments. Electric AUMA actuators successfully control flow of water and steam – in feedwater treatment plants and steam generation as well as in turbines, flue gas purification and cooling towers. They satisfy the highest demands for control accuracy, reliability, and safety.

INTEGRATION INTO ANY SITE CONTROL SYSTEMS

AUMA actuators are the perfect match for interfaces designed to the needs of power plant control system management. They safeguard uniform communication with all valves. Thanks to redundant fieldbus technology, data communication is particularly reliable.

CERTIFIED NUCLEAR ACTUATORS

AUMA supply electric actuators complying with the safety-critical duties in nuclear power plants. Actuators are qualified for both Inside and Outside Containment.



ENERGY



SUPERIOR AVAILABILITY

AUMA actuators provide dependable plant availability thanks to their renowned reliability. AUMA actuators are qualified for safety-related systems up to SIL 3. Extensive diagnostic functions allow integration into asset management systems.

AUMA powder coating excels by withstanding highly corrosive environments, for example, in cooling towers. Remote mounting to separate wall brackets safeguard AUMA actuator controls' services even in the case of significant vibration, high temperatures, and wherever actuator access is extremely difficult.

AUMA offer comprehensive maintenance concepts reaching as far as the complete service for power plant revisions.



- > THERMAL POWER PLANTS (COAL, GAS, OIL)
- > NUCLEAR POWER PLANTS
- > COGENERATION POWER PLANTS
- > DISTRICT HEATING
- > HYDROELECTRIC POWER PLANTS
- > GEOTHERMAL POWER PLANTS
- > SOLAR THERMAL POWER PLANTS
- > BIO GAS POWER STATIONS



ENERGY

accounts for 30 %
of total turnover

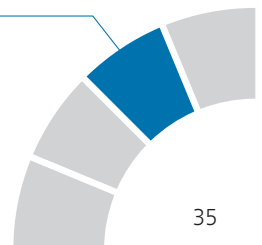



The background is a deep blue gradient with several thin, white, curved lines that sweep across the page from the left side. In the lower half, there is a dark, almost black silhouette of a hand holding a pen, positioned as if about to write. The lighting is dramatic, with bright highlights on the blue background and deep shadows in the silhouette.

OIL & GAS

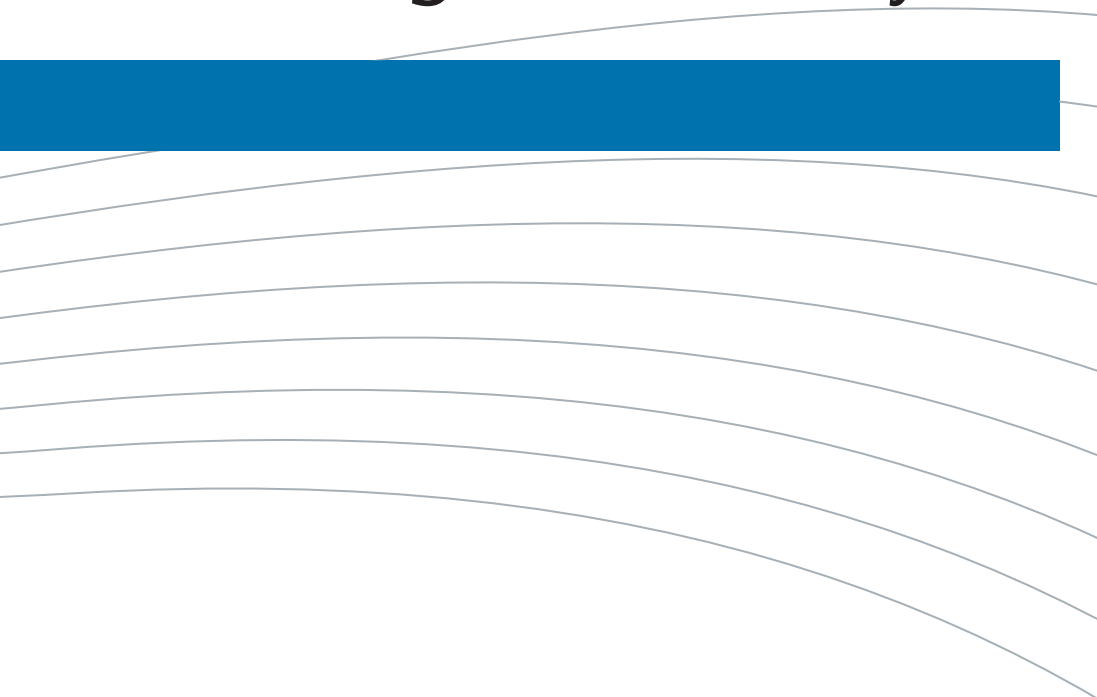

AUMA solutions
for the
oil and gas industry



Witness for safety

Oil & gas are crucial energy sources for modern society. They are extracted, processed, and distributed using most sophisticated technologies. AUMA actuators completely meet the challenging safety requirements of this market segment.

WORLDWIDE RECOGNITION AND AWARENESS

Notable companies in the oil and gas industry trust AUMA actuator solutions for their challenging duties. Whether exposed to the freezing temperatures of Siberia or the scorching heat of the Persian Gulf - AUMA actuators provide reliable and safe duty in extreme climatic conditions.

FIELDBUS

Fieldbus interfaces like Profibus DP, Modbus RTU, Foundation Fieldbus, DeviceNet as well as HART interfaces warrant seamless integration into the distributed control system. Redundant data communication considerably increases transmission security, in particular when covering long distances.



OIL & GAS



EXPLOSION PROTECTION AND SIL

AUMA actuators and actuator controls are approved and qualified for integration into potentially explosive atmospheres. They are certified for safety-related systems up to SIL 3. Actuators with fireproof housing provide reliable service even in the event of a fire.

ADVANCED DIAGNOSTICS

Thanks to their modern sensor technology and extensive diagnostic functions, our products are easily integrated into asset management concepts and safeguard plant performance and availability.



- > REFINERIES
- > PIPELINES
- > TANK FARMS
- > PLATFORMS
- > PUMPING STATIONS
- > GAS TANKS

OIL & GAS
accounts for 25 %
of total turnover

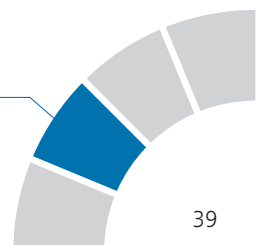



INDUSTRIAL AND SPECIAL SOLUTIONS





AUMA solutions for the industry

Versatile actuators for all situations

Process plants do have one thing in common: Liquids, gases or granules are fed and dosed to the individual process stages through pipelines and transported for further processing. In these applications, electric actuators for valve operation play a crucial role due to the high level of automation.

VARIED EXPECTATIONS AND DEMANDS

Thanks to our modular product portfolio with large torque ranges and comprehensive accessories, AUMA are your ideal partner for identifying your automation solutions to your plant specifications.

From simple opening and closing of valves to complex control duties with fine-tuned setpoint control – there is no limit to the span of feasible applications.

Simple operation, safe communication via modern controls and excellent reliability – this is just to name some of the varied customer benefits for favouring AUMA solutions.



INDUSTRIAL AND SPECIAL SOLUTIONS



EXTREME ENVIRONMENTS

AUMA actuators excel with their high corrosion protection, coping with most hostile and harsh environments prevailing in mining as well as paper and cement industries.

AUMA modulating actuators meet the demands for positioning accuracy and short reaction times in long-term service in the chemical and pharmaceutical industries.

Automation duties on ships require compact products: AUMA offer specifically designed actuators to comply with the space constraints.



- > CEMENT INDUSTRY
- > STEEL MILLS
- > PAPER INDUSTRY
- > HEATING, VENTILATION AND AIR CONDITIONING
- > SHIPBUILDING INDUSTRY
- > CHEMICAL INDUSTRY
- > FOOD INDUSTRY
- > PHARMACEUTICAL INDUSTRY
- > MINING
- > REFRIGERATION ENGINEERING

INDUSTRY
accounts for 15 %
of total turnover

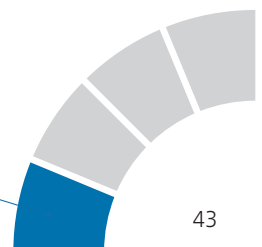



PRODUCTS

Individual solutions
for individual challenges

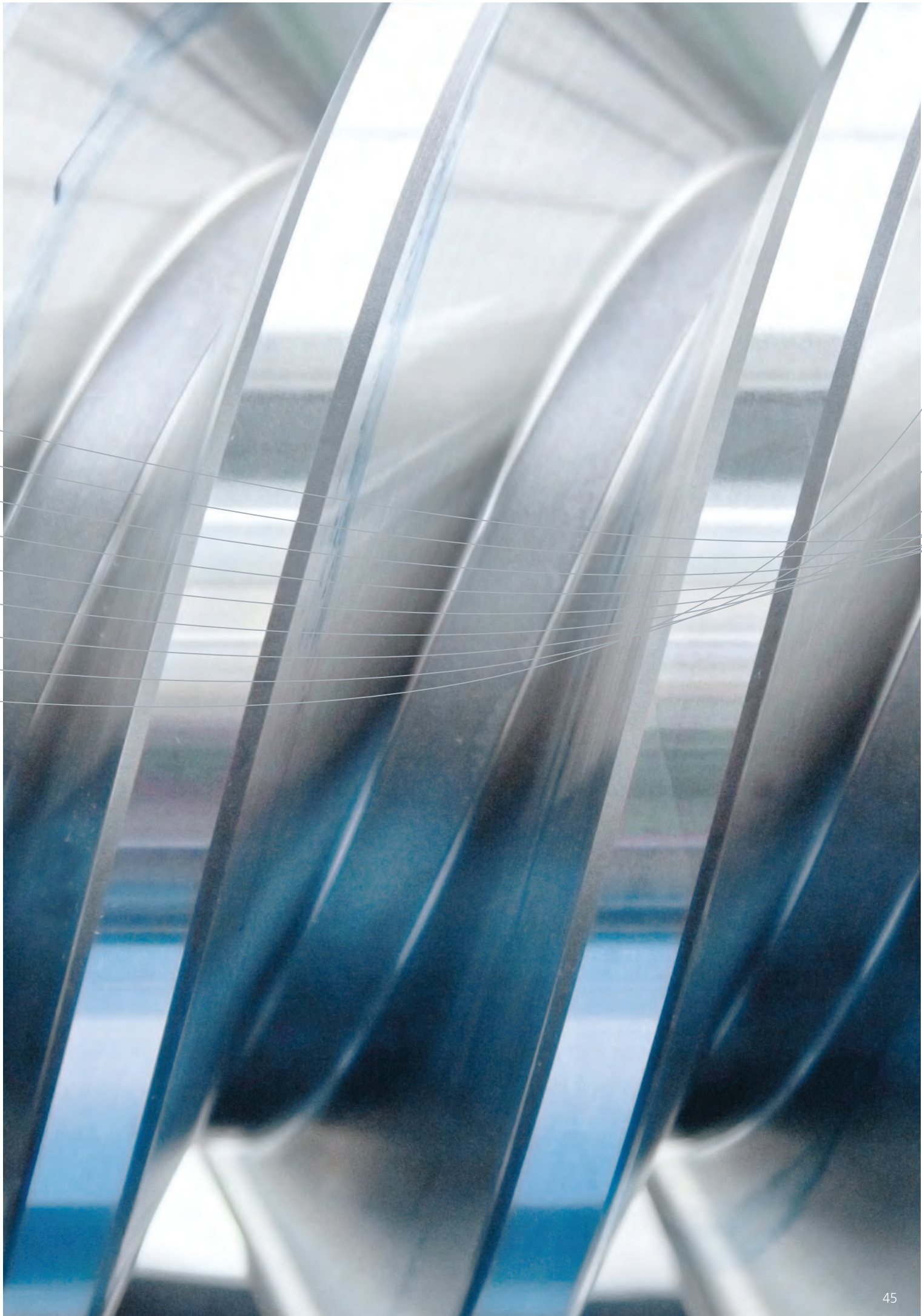

Modular all-rounders

SA and SQ actuators are robust and versatile. Equipped with AM or AC integral controls, they can be implemented into any automation system. Combinations with AUMA gearboxes result in high performance multi-turn, part-turn, lever, and linear actuators.



MODULAR SOLUTIONS FOR THE FUTURE

Thanks to their easy handling, reliability, long service life – even under most unfavourable and harsh environments – SA multi-turn actuators have earned their outstanding reputation. The SQ part-turn actuators, based on the same established and sound expertise, have been successfully launched.

These modular actuators adapt perfectly to any mounting requirements, aided by their flexible device positioning and their variety of sizes and version available. They are compatible across all product generations and allow for easy retrofitting.

At interface level between valve and control system, our actuators with integral actuator controls warrant for safe communication and uniform operation concepts throughout the plant.



SA MULTI-TURN ACTUATORS AND SQ PART-TURN ACTUATORS



SA MULTI-TURN ACTUATORS

- > Automation of gate and globe valves
- > Sizes: 07.2 – 16.2 and 25.1 – 48.1
- > Torques: 10 Nm – 32,000 Nm
- > Output speeds: 4 rpm – 180 rpm
- > SAR version for modulating duty
- > SAEx/SAREx version for potentially explosive atmospheres

SQ PART-TURN ACTUATORS

- > Automation of butterfly valves, ball and plug valves
- > Sizes: 05.2 – 14.2
- > Torques: 50 Nm – 2,400 Nm
- > Operating times: 4 s – 100 s
- > Setting angle: 45° – 180°
- > SQR version for modulating duty
- > SQEx/SQREx version for potentially explosive atmospheres

AC CONTROLS

- > Microprocessor-based controls with comprehensive functions
- > Suited for complex modulating applications
- > Large, graphic display
- > Modern sensor technology for detailed diagnostics
- > Plant Asset Management
- > Parallel and fieldbus interfaces

AM CONTROLS

- > Simple controls providing basic functions



COMBINATIONS



SA MULTI-TURN ACTUATORS WITH GK MULTI-TURN GEARBOXES

- > Automation of gate valves and double-stem gate valves
- > Torques: up to 16,000 Nm
- > Offset of effective direction by 90°



SA MULTI-TURN ACTUATORS WITH GST MULTI-TURN GEARBOXES

- > Automation of gate valves
- > Torques: up to 16,000 Nm

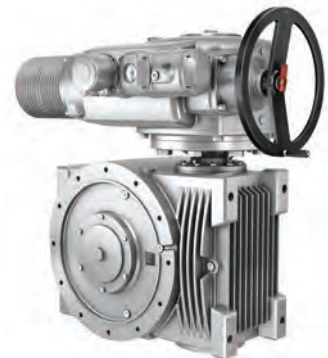

SA MULTI-TURN ACTUATORS WITH GHT MULTI-TURN GEARBOXES

- > Automation of gate and globe valves
- > Torques: up to 80,000 Nm
- > Output speeds: 2 rpm – 16 rpm

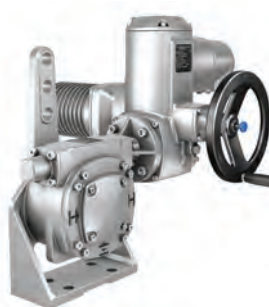

**SA MULTI-TURN ACTUATORS
WITH GS WORM GEARBOXES**

- > Automation of butterfly valves, ball and plug valves
- > Torques:
up to 675,000 Nm
- > Operating times for 90°
9 s – 392 s

**SA MULTI-TURN ACTUATORS
WITH LE LINEAR THRUST
UNITS**

- > Automation of globe valves
- > Thrusts: 4 kN – 217 kN
- > Strokes: 50 mm – 500 mm
- > Linear speeds:
20 mm/min – 360 mm/min

**SA MULTI-TURN ACTUATORS
WITH GF LEVER GEARBOXES**

- > Automation of butterfly valves with lever arrangements
- > Torques:
up to 45,000 Nm
- > Operating times for 90°
17 s – 392 s

**SQ PART-TURN ACTUATORS
WITH BASE AND LEVER**

- > Automation of butterfly valves with lever arrangements
- > Torques:
100 Nm – 2,400 Nm
- > Operating times for 90°
4 s – 63 s

Small and compact

With this type range, AUMA found the perfect concept to cope with space constraints and small valves. Thanks to our compact type range and speed-controlled motors, we successfully managed to satisfy a market niche which had previously to rely on costly pneumatic solutions.



VERSATILE IMPLEMENTATION

Swift installation and clear operation invite our small multi-turn and part-turn actuators for use in the water industry and the shipbuilding sector. As M version, their housings are made of bronze for high seawater resistance and have proven themselves in their mission on ships.

INTEGRAL CONTROLS

Actuator controls are integral part of the compact actuators. Push buttons allow for swift and intuitive operation, via laptop or the control system. Standardised fieldbus interfaces like Profibus, Modbus, and Foundation Fieldbus allow for device integration into commonly used control systems.



SVC & SVM MULTI-TURN ACTUATORS AND SGC & SGM PART-TURN ACTUATORS



SVC MULTI-TURN ACTUATORS

- > Automation of globe valves
- > Sizes: 05.1 – 07.5
- > Torques: 10 Nm – 100 Nm
- > Output speeds: 0.6 rpm – 22 rpm
- > SVCR version for modulating duty



SVM MULTI-TURN ACTUATORS

- > Automation of globe valves
- > Housing made of bronze for harshest environments
- > Sizes: 05.1 – 07.5
- > Torques: 10 Nm – 100 Nm
- > Output speeds: 0.6 rpm – 22 rpm
- > SVMR version for modulating duty



SGC PART-TURN ACTUATORS

- > Automation of butterfly valves, ball and plug valves
- > Sizes: 04.1 – 12.1
- > Torques: 25 Nm – 1,000 Nm
- > Operating times for 90°: 4 s – 90 s
- > SGCR version for modulating duty



SGM PART-TURN ACTUATORS

- > Automation of butterfly valves, ball and plug valves
- > Housing made of bronze for harshest environments
- > Sizes: 04.1 – 12.1
- > Torques: 25 Nm – 1,000 Nm
- > Operating times for 90°: 4 s – 90 s
- > SGMR version for modulating duty

Advice and service throughout the entire product life

We at AUMA strive for long-term customer satisfaction and partnership by warranting for safe and smooth operation of our actuators. We attribute great importance to customised advice and comprehensive service – throughout our products' lifetime.

SERVICES





COMPREHENSIVE SERVICE

Our customers worldwide appreciate the outstanding quality of the AUMA service – and this for a good reason: It is important to us to provide fast and unbureaucratic support and share our wealth of knowledge with you. With our versatile service portfolio, we are your competent partner from installation and commissioning to training, maintenance, and overhaul or repair right through to global availability and provision of spare parts.

QUALIFIED EXPERTS

With internal and external training schemes, our service engineers excel by their expertise for AUMA actuators. These experienced engineers are perfectly equipped with tools, test appliances, and spare parts to provide customised and fast on-site support.

TAILORED MAINTENANCE

Preventive maintenance maximises plant availability. In compliance with the specified application conditions, we develop individual and tailored maintenance concepts.

Maintenance of our explosion-proof devices is exclusively performed by our approved expert staff, complying to legal regulations, heeding defined intervals. We offer a comprehensive service for power plant revisions with individually designed and standardised control plans.

RETROFITTING AND CUSTOMISED PRODUCTION

There is no such thing as "impossible" with AUMA. Special and challenging installation conditions require special and customised solutions: Especially for buried service or when modernising existing plants where valve attachments are frequently not complying with standards. We offer extensive accessories and manufacture pedestals, lever arrangements, and other adapters to customer needs.

Our actuator controls' software is adapted when and where needed, for example for automating customised valves.

Products you can trust

Today.

Independent test authorities keep certifying the outstanding standard of AUMA products. Comprehensive vendor list approvals of international groups and authorities clearly show our global customers' trust in AUMA products. Worldwide certifications according to ISO 9001:2008 and ISO 14001:2004 are the flag ship for the quality management throughout the AUMA group.

AUMA products are internationally approved and qualified for potentially explosive atmospheres and for safety-related applications up to SIL 3.

The international fieldbus organisation certify conformity of AUMA actuators and actuator controls with all commonly used fieldbus systems like Foundation Fieldbus, Profibus, Modbus, and DeviceNet.

QUALIFICATIONS AND CERTIFICATES

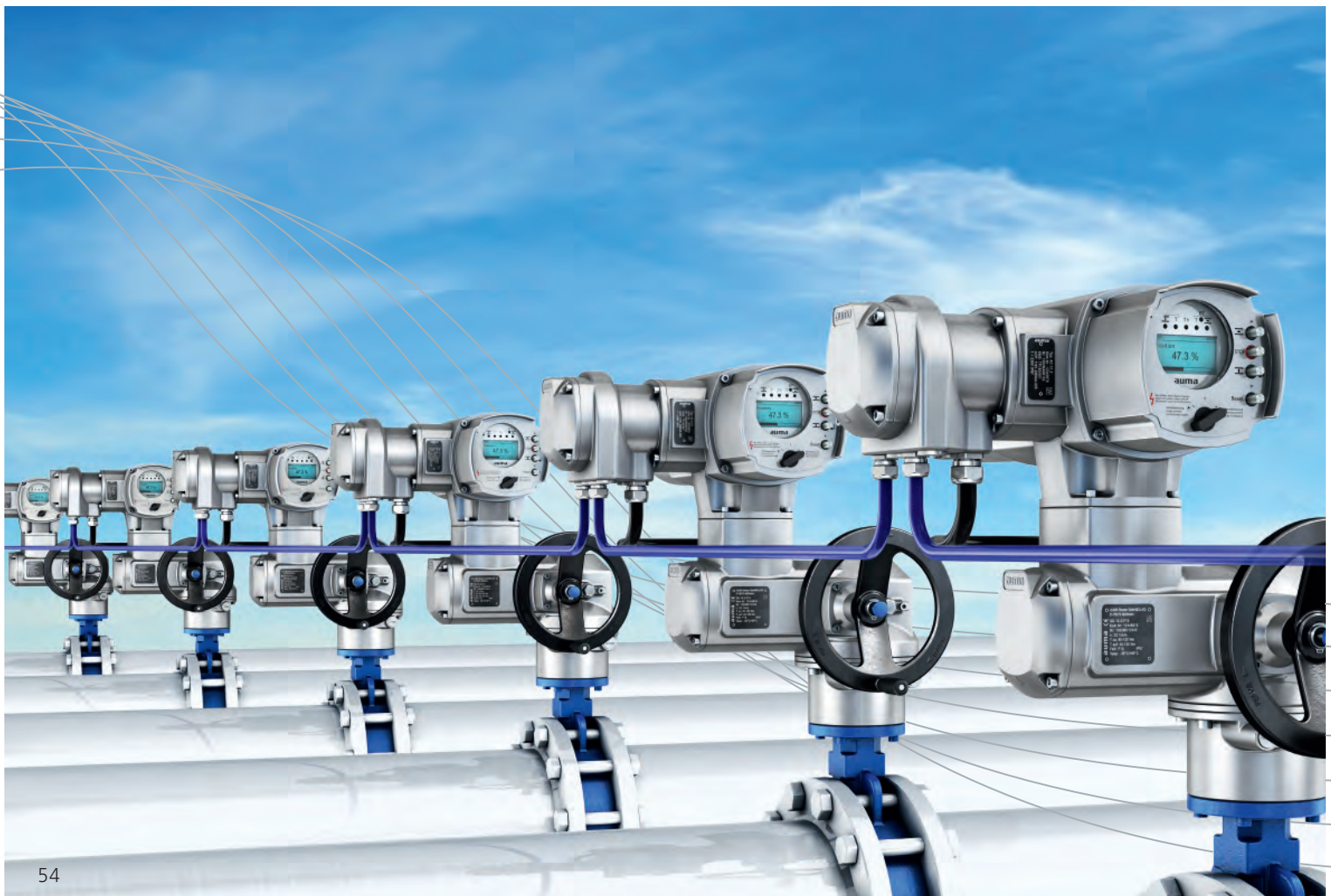

And tomorrow.

Our commitment beyond boundaries.

Our investment in staff, development, and production create long-term perspectives. As an owner-managed private enterprise, our customers value us as reliable and competent partners.

Flexibility and innovation help us to cope with our challenges of tomorrow. AUMA solutions provide stable and long-term security of investment.

This is AUMA.



AUMA Riester GmbH & Co. KG

Aumastr. 1
D-79379 Muellheim
Tel +49 7631-809-0
Fax +49 7631-809-1250
riester@auma.com

AUMA subsidiaries or representatives
are implanted in more than 70 countries. For
detailed contact information, please refer to
www.auma.com