

Weather proof actuators  
with 3.XMP-SIL & Data logging

SA3 - SA100

SAR3 - SAR100



## Table of Content

Sl. No.	Content	Page No.
<b>1</b>	<b>Safety Instructions</b>	<b>3-6</b>
1.1	Basic information on safety	
1.2	Range of application	
1.3	References and symbols	
1.4	Name plate	
1.5	Transport, storage and packaging	
<b>2</b>	<b>Introduction</b>	<b>7-10</b>
<b>3</b>	<b>Front panel details</b>	<b>11-14</b>
3.1	Selector switch	
3.2	LCD screen & LED indication	
<b>4</b>	<b>Modes of operation</b>	<b>15-38</b>
4.1	Program mode	
4.1.1	EDIT/VIEW option of program mode	
4.1.2	EDIT mode parameters	
4.1.3	Remote settings	
4.1.4	Relay settings	
4.1.5	Intermediate position setting	
4.2	Diagnostic mode	
4.3	Calibration mode	
4.3.1	Limit open calibration	
4.3.2	Limit close calibration	
4.3.3	Close limit and open limit calibration through counter gears/ limit switches	
4.3.4	Setting of Mechanical position indicator	
4.3.5	Do's and Don'ts - Troubleshooting tips	
4.3.6	Change torque trip value	
4.3.7	Preset torque	
<b>5</b>	<b>Annexure</b>	<b>39-44</b>
<b>6</b>	<b>Disposal and recycling</b>	<b>45</b>

## 1 Safety Instructions

### 1.1 Basic information on safety

**Safety instructions / warnings** All personnel working with this device must be well-versed with the safety and warning instructions in this manual and observe the instructions given. In order to avoid personal injury or property damage, the safety instructions and warning signs must be observed carefully. Kindly follow Common Electrical and Electronic related safety instructions according to industrial standards. The main mechanical safety instructions are fixed on the actuators as shown below.

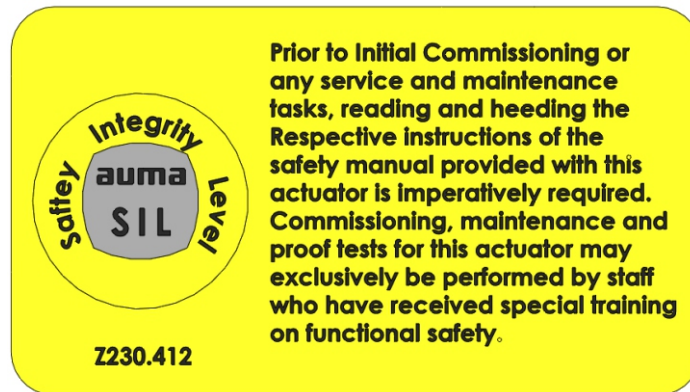

**Warnings and notes** Failure to observe the warnings and notes may lead to serious injuries or damage. Qualified personnel must be thoroughly familiar with all warnings and notes in these operation instructions. Correct transport, proper storage, mounting and installation, as well as careful commissioning are essential to ensure a trouble-free and safe operation. The following references draw special attention to safety-relevant procedures in these operation instructions. Each is marked by the appropriate pictograph.

 **This pictograph means: Note!**

“Note” marks activities or procedures which have major influence on the correct operation. Non-observance of these notes may lead to consequential damage.

 **This pictograph means: Warning!**

“Warning” marks activities or procedures which, if not carried out correctly can affect the safety of persons or material.

**Qualification of staff** Assembly, electrical connection, commissioning, operation and maintenance must be carried out exclusively by suitably qualified personnel having been authorized by the end user or contractor of the plant only. Prior to working on this product, the staff must have thoroughly read and understood these instructions and, furthermore, know and observe officially recognized rules regarding occupational health and safety.

Work performed in potentially explosive atmospheres is subject to special regulations which have to be observed. The end user or contractor of the plant is responsible for respect and control of these regulations, standards and laws.

**Commissioning** Prior to commissioning, it is important to check that all settings meet the requirements of the application. Incorrect settings might present a danger to the application, e.g. cause damage to the valve or the installation. The manufacturer will not be held liable for any consequential damage. Such risk lies entirely with the user.

**Operation** Prerequisites for safe and smooth operation:

- Correct transport, proper storage, mounting and installation, as well as careful commissioning.
- Only operate the device if it is in perfect condition while observing these instructions.
- Immediately report any faults and damage and allow for corrective measures.
- Observe recognized rules for occupational health and safety.
- Observe the national regulations.

**Protective measures** The end user or the contractor is responsible for implementing required protective measures on site, such as enclosures, barriers, or personal protective equipment for the staff.

**Maintenance** AUMA India multi-turn actuators require very little maintenance but they need to be tested regularly for its correct functioning. After commissioning, check the actuator for damage to paint finish. Do a thorough touch-up to prevent corrosion. Correct commissioning is a prerequisite for reliable service. Seals made of elastomers are subject to aging and must therefore regularly be checked and, if necessary, exchanged. It is also very important that the O-rings at the covers are placed correctly and cable glands fastened firmly to prevent ingress of dust or water.

We recommend additionally:

- If operated seldom, perform a test run about every 6 months. This ensures that the actuator is always ready to operate. The version of actuators discussed in this manual have an option for Partial Valve Stroke Test (PVST) to check if the actuator is healthy.
- Approximately six months after commissioning and then every year check bolts between actuator and valve for tightness. If required, tighten by applying appropriate torques.
- The gear housing is filled with lubricant in the factory. This filling lasts for several years of service.
- Corrosion of paint damage parts must be prevented through touch up.

Any device modification requires the consent of the manufacturer.

## 1.2 Range of application

AUMA India actuator controls are exclusively designed for the operation of AUMA India actuators. Other applications require explicit (written) confirmation by the manufacturer. The following applications are not permitted.

- Motor control
- Pump control

No liability can be assumed for inappropriate or unintended use.

Observance of these operation instructions is considered as part of the device's designated use.

## 1.3 References and symbols

The following references and symbols are used to provide information of the basic actuator commands to the customer. They are:







Symbol for CLOSED (valve closed)



Symbol for OPEN (valve open)



Symbol for STOP (valve stop)

- Notice**  The actuator can be mounted in any position. The actuator is suitable for short-time duty.
-  The Maximum rated torque and thrust should not be applied over full range of travel, except for valve with short stroke. The maximum rated torque(Nm) can be applied to 10% of travel and remaining 90% of travel can be applied with 30% of rated torque(Nm).
-  Bore in coupling flange must have sliding fit on the input shaft. Excessive seating may damage the actuator during fitting.
-  Positioning of actuator on the valve is made easy by spigot on mounting flange. The corresponding seating should be made to grade H8. Check the proper seating.

<b>Tightening torque for bolts</b>				
	Strength class 8.8		Strength class 10.9	
<b>Standard metric thread</b>	<b>Assembly preload [kN]</b>	<b>Tightening torque [Nm]</b>	<b>Assembly preload [kN]</b>	<b>Tightening torque[Nm]</b>
<b>M 1.6</b>	0.538	0.18	0.79	0.27
<b>M 2</b>	0.895	0.38	1.32	0.56
<b>M 2.5</b>	1.49	0.78	2.19	1.1
<b>M 3</b>	2.24	1.4	3.3	2
<b>M 4</b>	3.88	3.1	5.7	4.5
<b>M 5</b>	6.36	6.1	9.34	9
<b>M 6</b>	8.97	11	13.2	15
<b>M 8</b>	16.5	25	24.2	37
<b>M 10</b>	26.2	51	38.5	75
<b>M 12</b>	38.3	87	56.2	128
<b>M 16</b>	72.4	214	106	314
<b>M 20</b>	117	431	166	615
<b>M 24</b>	168	742	239	1057
<b>M 30</b>	269	1489	383	2121
<b>M 36</b>	393	2594	560	3695



**Additional Tips**

- Do not operate the actuator with improper wiring.
- Do not interchange the cards without checking the e-pac code.
- Do not interchange the e-pac without checking the **TOLR** rating.
- Improper sealing of cable glands resulting in water entry at site will inadvertently damage all the electronic cards.
- Do not operate the actuator in manual mode while electrically operating.
- Please check the input voltage rating of the motor before giving supply.
- Do not run the NORM actuator without panel.
- Do not bypass the thermoswitch connection in the loop.

## 1.4 Name Plate

Each actuator will have a nameplate associated with it which contains several important details. Please locate where the plate is present in your actuator. The information provided in the nameplates is delineated below. These are required to ensure our support after supply. There are several variations of nameplates available. Please match your actuator nameplate with the appropriate one below to obtain the required information. You are requested to furnish the below details of the name plate while ordering spare parts/after sales support.

The Works Number mentioned in this name plate gives other details besides giving the EPAC Version. The actuator type gives the maximum torque, RPM of the actuator, weather proof/explosion proof and on-off/regulating duty.

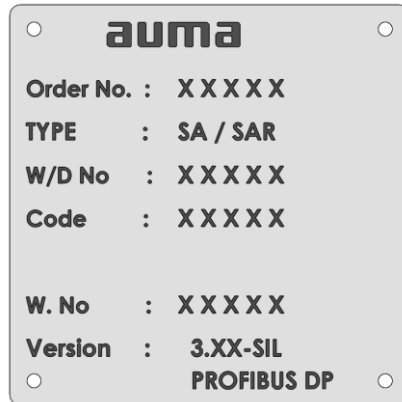

## 1.5 Transport, storage and packaging

**Transport** Transport to place of installation in sturdy packing. If mounted together with actuator, attach ropes or hooks for the purpose of lifting by hoist only to the gearbox and not to the actuator and use eye bolt as per table 1.

- √ Transport to the place of installation (till last destination).
- √ Avoid packages from exposing to open atmosphere during transit.
- √ Protect against rains.

**Storage**

- √ Store in well-ventilated, dry room.
- √ Protect against floor dampness by storage on a shelf or on a wooden pallet.
- √ Cover to protect against dust and dirt. Apply suitable corrosion protection agent to bare surfaces.
- √ In case gearboxes are to be stored for a long period (more than 6 months). Protect bare surfaces, in particular the output drive parts and mounting surface, with long-term corrosion protection agent.
- √ Check for corrosion approximately every 6 months. If first signs of corrosion show, apply new corrosion protection.

Type of enclosure is mentioned on the name plates.

**Packaging**

- √ Our products are protected by special packaging for the transport ex-works.
- √ The packaging consists of environmentally friendly materials which can be easily separated and recycled.
- √ For the disposal of the packaging material, we recommend approved disposal agency.
- √ We use the following packaging materials: Wooden material boards (OSB) / cardboard / paper, PE sheet.

## 2 Introduction

AUMA India has developed a new range of electric actuators with intelligent integral starter using microcontrollers for weatherproof applications that has the ability to store events and other upgraded features. The actuators support both ON-OFF and Regulating Duty and can also be run in Inching or Non-Inching mode depending on the selection.

The important features of these electric actuators are as explained below:

- LCD graphical display & LED indication** Options can be selected by using the selector switches, rotating knob based on the instructions displayed on the LCD screen. Information on faults/statuses can be obtained from the 6 LEDs next to the LCD. The 6 LEDs are configurable as per user requirement before-hand. LCD screen facilitates easier understanding of status, operation and parameter setting details. More information regarding this is described in section 3.
- Inbuilt front panel option selection** Different features/options of the actuator can be configured using software. This is done using the selector switches, rotating knob based on the instructions displayed on the LCD screen that is present on the front panel. More information regarding this is described in section 3.
- Interfaces** These actuators are capable of supporting different types of interfaces like Remote – 4 Wire / 2 Wire Make/Break, 4-20 mA Regulating Duty, Bluetooth & MODBUS-RTU.
- Emergency stop - ESD** ESD feature is configured to run in Close direction on enabling ESD as a default setting. One needs to enable ESD and set its behavior in Program Mode for it to function. An ESD via MODBUS option is also available that needs to be enabled in Program Mode. ESD Operation can be configured for OPEN/CLOSE/STAY. One can choose to set ESD on TOLR Ignore, TH Ignore, Space heater Fail Ignore, OFF Ignore. This means that ESD operation would occur irrespective of these faults. One must enable ESD on program mode and set its behavior (ESD Open/Close). An ESD NO/NC configuration is also available that can be configured in Program mode. ESD feature now can be carried out using an external 24VDC supply also.
- Event storage & data logging option** These actuators comes with an option to store events such as faults, statuses, number of starts (Open in Local/Remote) etc. using a Bluetooth module. The events are stored in a flash memory and can be read via Bluetooth. The data logged will have a real time stamp and can be downloaded using a user-friendly application called AUMA India Utility Software onto a PC/ Laptop with Bluetooth connection. About 43691 events can be stored at a time using this module. AIUS is also used in assisting commissioning and diagnosing the actuators. Device Tag is customer configurable. Remote Operation of actuator through Bluetooth is also available.

The available events are as follows:

- Number of Starts (Open and close in specified duration)
- Open and close Command with Selector Switch Position
- Tripping Torque Profile (Non-Intrusive)
- Faults.
  - Loss of Phase
  - 24V Fail
  - Thermal Switch Trip
  - Torque Switch Trip
  - Control Supply Failure
  - TOLR

- Selector Switch Change.
- End Position
- ESD

More details of this feature are available in AIUS User Manual (Doc. No.: 4-AIUS-MANUAL-39396).

**Partial valve stroke test (PVST) option**

This feature is used in checking correct functioning of valves which are not operated for a long period. When PVST is triggered the valve moves to particular percentage and come back to the same end position and gives PVST result. The features are:

- PVST can be triggered externally through a switch or via MODBUS.
- PVST command can be given through MODBUS using dedicated registers.
- PVST Position can be configured in the following two ways.
  - From Open End
  - From Close End
- PVST Percentage can be set to any of the three options.
  - 5%, 10%, 15%
- PVST Failure: This failure occurs when the PVST command doesn't take place after a specified time (that is specific to actuators based on its RPM and No. of Turns). This failure is indicated by using any one of the programmable relays present in your module.

**Inhibit option**

Inhibit is an interlock for open close operations. Inhibit Operation can be Enabled or Disabled in Software (Program Mode). In this module, separate terminals for Inhibit Open and Inhibit Close are available. Based on this, Open/Close Commands can be inhibited.

**Local control station (LCS) priority**

When this feature is enabled, the user can control the actuator in remote 4 –wire mode of operation even when in 4-20mA or MODBUS mode of Operation.

---

**Remote local stop**

This option is also software configurable and can be enabled in Program Mode. The actuator should stop running in Remote Mode when open/close rotary knob rotated in the Actuator Front Panel. No commands should be accepted by the actuator until it is reset.

---

**Timer mode**

Timer mode is used to control the valve movement. This mode allows us to open or close the valve slowly towards the end position after reaching a certain distance with continuous operation.

Configurable Options:

- Open timer start Valve Position: The user has to set the valve position at which this Timer mode should go on for Open Command.
- Open ON time: This parameter decides the amount of time (in s) the actuator runs in Open direction before shutting off for Open OFF time (in s). This continues to happen until the respective limit switch is hit (unless the switch is bypassed).
- Open OFF time: This parameter decides the amount of time (in s) the actuator shuts off before running in open direction for Open ON time (in s). This continues to happen until the respective limit switch is hit (unless the switch is bypassed).
- Close timer start Valve Position: The user has to set the valve position at which this Timer mode should go on for Close command.
- Close ON time : This parameter decides the amount of time (in s) the actuator runs in Close direction before shutting off for Close OFF time (in s).This continues to



- happen until the respective limit switch is hit (unless the switch is bypassed).
  - Close OFF time: This parameter decides the amount of time (in s) the actuator shuts off before running in open direction for Open ON time (in s). This continues to happen until the respective limit switch is hit (unless the switch is bypassed).
- 

### **Programmable relays**

As per standard, two relays are given for customer end information - Fault Relay & Optional Relay 1. There are about 6-8 more additional relays that have been added along with this module. Each of these relays can be configured for the following 27 faults / statuses as given below.

- List of available relays
    - Fault Relay
    - Assignable Relay (5relays)
    - Latching Relay ( 2 relays)
  - Available Programmable options are:
    - Opened (Open Limit Trip)
    - Closed (Close Limit Trip)
    - Remote Local stop
    - Local Stop
    - Open Torque Trip
    - Close Torque Trip
    - Loss of Phase
    - TH-Trip
    - TOLR Trip
    - Control Supply Fail
    - Phase reversal
    - Jammed Valve
    - Power ON
    - Program Mode Indication
    - SP Reached ( via DAC/MODBUS)
    - Selector SW LOCAL
    - Selector SW OFF
    - Selector SW REMOTE
    - ESD Pressed
    - 24V DC Fail
    - Space Heater Fail
    - Running Open
    - Running Close
    - Remote Selector SW EN
    - PVST Fail
    - Intermediate Pos
    - 4-20mA Signal Fail
- 

### **Real time clock (RTC)**

This module has a Real time clock that is used to obtain the time-stamp for Event logging. The RTC can be configured by AUMA Utility Software or by manually setting the RTC in Program Mode settings. The RTC is powered by a Super Capacitor when the power is off which is another added feature of this module. The Super Capacitor takes about 2 hours to charge and can supply power up to 20 days to the RTC.

---

### **Power supply**

The Power Supply Card used in this module has several new features. The features are as follows:

- Under Voltage Protection
- Over Voltage Protection

- Short Circuit Protection
- Uses Single Transformer with selectable voltage & frequency range
- Voltage Range : 360VAC to 480VAC
- Frequency Range: 47.5Hz to 63Hz.

**NOTE:** The features supported by your actuator is with respect to the wiring diagram (WDP) provided with it. Please remember that it might not have all the features described in this document.

**Customer Connections/  
terminals**

ELECTRICAL CONNECTION WITH AUMA 64 PIN CONNECTOR (WITH PROFIBUS)

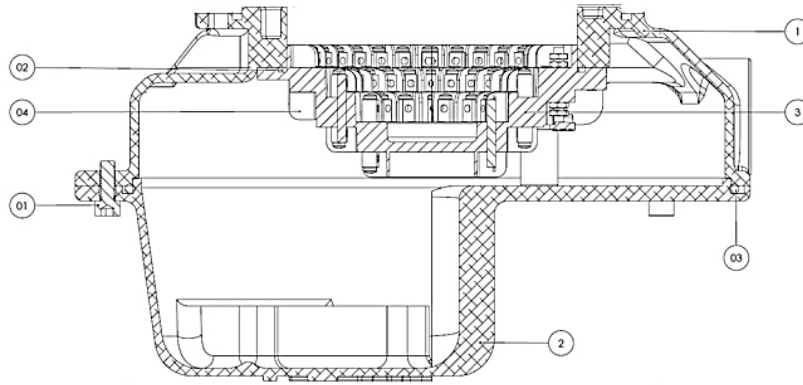

Part No	Description	Part No	Description
1	KLK COVER	01	SOCKET HEAD CAPITIVE SCREW
2	TERMINAL COVER FOR SIL	02	O-RING
3	64 PIN CONNECTOR	03	O-RING
		04	M4 SLOT HEAD CAPITIVE SCREW

ELECTRICAL CONNECTION WITH AUMA 64 PIN CONNECTOR (WITHOUT PROFIBUS)

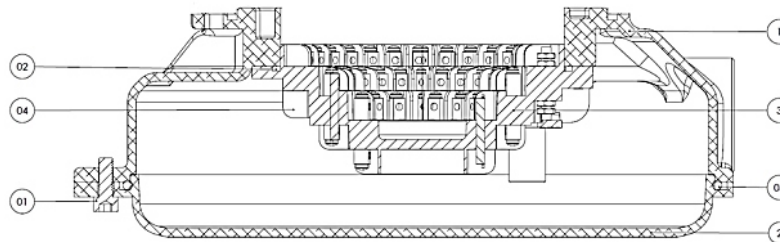

Part No	Description	Part No	Description
1	KLK COVER	01	SOCKET HEAD CAPITIVE SCREW
2	TERMINAL COVER	02	O-RING
3	64 PIN CONNECTOR	03	O-RING
		04	M4 SLOT HEAD CAPITIVE SCREW

### Mounting to valve / gearboxes

#### Note

- Prior to mounting, the multi-turn actuators must be checked for any damage.
- Damaged parts must be replaced by original spare parts.

Mounting is easily carried out with valve shaft / gearbox shaft pointing vertically upward. However, mounting is also possible in any other position as well.

The actuator is delivered ex-works in position CLOSED.

#### Note

- Check if mounting flange fits valve / gearbox.
- spigot at flange should be loose fit.

### Output drives

Output drive type 'A' (Fig. 1)

This type is with stem nut. stem nut will be bored to pilot bore. Finish machining of nut to be carried out by customer as follows:

- Remove mounting flange (1) by loosening the bolts (2)
- Loosen ring nut (3) after unlocking grub screw (7) and take out stem nut (4) along with thrust bearings (5).
- Drill, bore and cut threads as required.
- Clean machined component and reassemble the output drive after applying ball bearing grease to thrust bearings.
- press grease through grease nipple (6) with grease gun.
- Thoroughly clean the mounting faces of output drive and valve.
- Apply small quantity of grease to stem of valve.
- Assemble the output drive to valve stem by slowly rotating the stem nut by suitable tool to engage the claws of the stem nut.
- After full engagement of nut, clamp the output drive to valve by using suitable bolts (threads at M).
- Lower the actuator on to the output drive and rotate the hollow drive shaft of actuator by engaging manual drive of actuator and rotating by hand wheel.

Output drive type B, C, D, E (Fig. 2):

Type B : Plug Sleeve

Type C : Dog coupling

Type D : Stub shaft

Type E : Bore with keyway

The above drives can be easily mounted to the actuator / gearbox as follows:

- Check whether bore and keyway match the input shaft of valve or gearbox.
- Output drive need not be removed from the actuator.
- Place the actuator with output drive on to the valve and engage the output of actuator (keyway or key of Type E) with the valve by slowly rotating the handwheel of actuator after engaging manual drive.
- Fasten valve flange to output drive flange with suitable bolts (bolt to at least quality grade H8). Refer table 'Tightening torque for bolts' for approximate tightening torques.

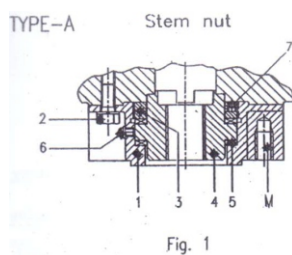

Fig. 1

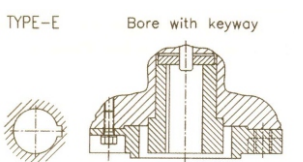
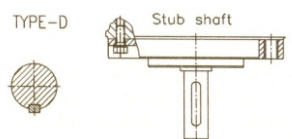
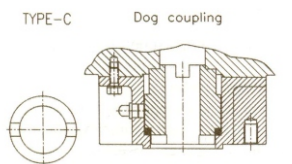
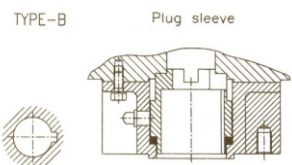
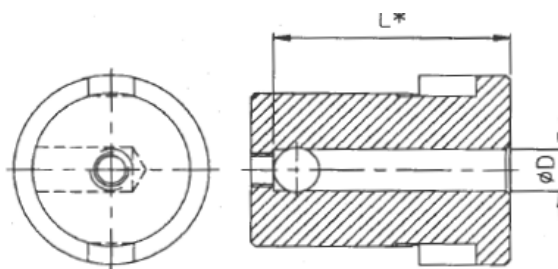

Fig. 2

**Procedure for enlarging  
the pilot bore of 'E' type  
output drive sockets used  
in actuators**



Actuator Model	Pilot bore Dia (D)	Max bore Dia	Max bore Dia
AI12	10	32	67

Dismantle the Drive socket by loosening draw bolt part Enlarge the pilot bore to required size.

Enlarge bore length of the drive socket shall not exceed the length L\* as indicated in the table. Key way position should be in line with the relief hole provided in the drive socket. The hole is provided to do the keyway slotting on slotting machine.

### 3 Front panel details

This section outlines the front panel details of actuators. The functions of each of these components are discussed below.

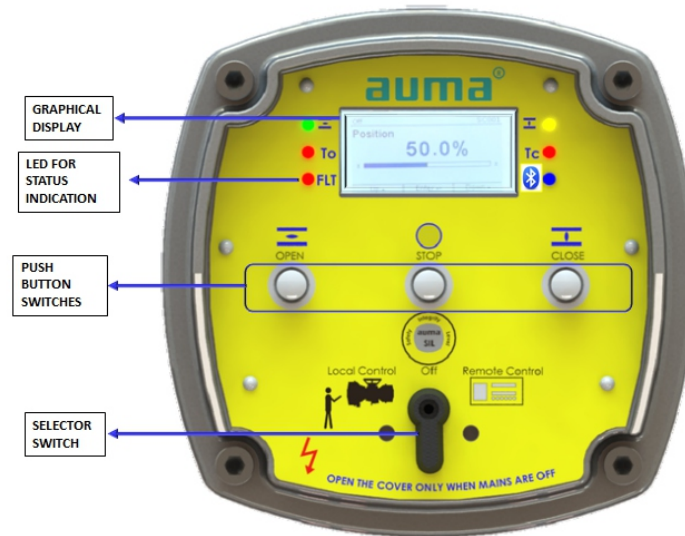

#### 3.1 Selector switch

Two rotary selector switch configurations are available.

1. There are 3 modes available: OFF, ESC & ENTER.
2. There are 2 states available: UP & DOWN.

#### 3.2 LCD screen & LED indication

**LCD screen** A graphical LCD is designed for the new actuator series. The LCD has scroll in (up down feature) and an Enter that can be operated through Hall Effect selector switches.

This LCD broadly has two types of screens: Setting screens and Main screens.

Each screen has a specific number identification. A new navigation feature is added, for LCD screens. If a particular screen number is entered, then the screen navigates to the respective display screen.

On power up, the screen is as indicated below.

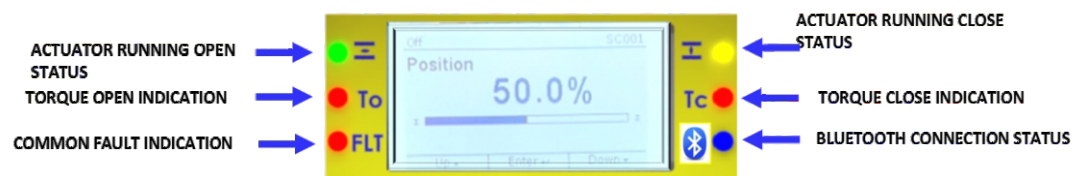







**Fig. : 3.XMP Non-intrusive with Bluetooth LED & LCD screen**

The basic LCD view is split into two lines. The first line shows the status details - The left half shows selector switch position status and the actuator running status alternatively. The right half of the first line represents Valve Position (VP) in terms of percentage. The valve position display feature is optional. If required, an appropriate Electronic Position Transmitter (EPT) must be chosen for this feature. Please contact AUMA India for more information.

The second line is used to represent only faults. The faults/warnings if any toggle in the sequence of occurrence. The details are as shown in the Fig.

Information regarding the running indication of the actuator (status) and faults are indicated by the LEDs present on the left side of the LCD screen which is shown in the Fig.

**LED indication** One can configure the four LEDs on the display module to represent different conditions. The default LED settings are as below:

COLOR	INDICATION	MODE
GREEN		If LED is blinking then actuator is running in OPEN direction. If LED is continuously ON then actuator is fully OPENED. If LED is OFF – then actuator is in Mid-Travel.
AMBER		If LED is blinking then actuator is running in CLOSE direction. If LED is continuously ON then actuator is fully CLOSED. If LED is OFF – then actuator is in Mid-Travel.
RED		Torque open trip indication
RED		Torque close trip indication
RED		If LED is continuously ON -- Fault Condition If LED is OFF – No fault Condition
BLUE		Default: OFF If LED ON: Paired and Connected with AUMA India Utility Software/ Whenever BT is connected

## 4 Modes of operation

For any device diagnostics and settings, there are two modes available. EDIT and VIEW. EDIT can be used whenever setting needs to be changed and VIEW can be used to see the already set settings.

This section describes about the modes available for selection in this module. The options are:

- **MODE 1** - Program mode
- **MODE 2** - Calibration mode
- **MODE 3** - Diagnostic mode

There are several options/settings that are available in each of these modes. These are discussed below.

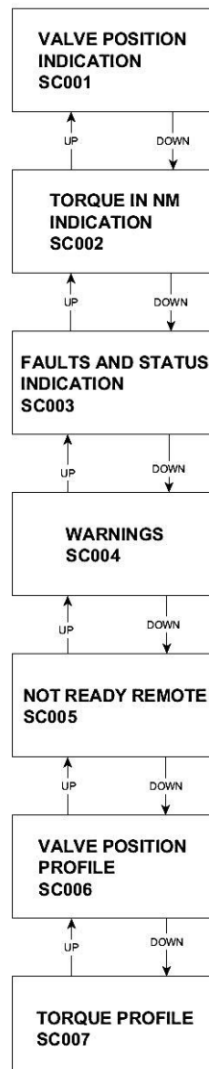
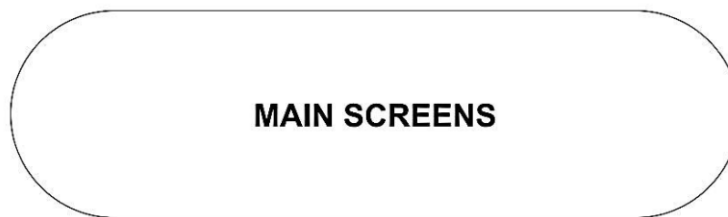

## 4.1 Program mode

The push buttons on the Front Panel can be used for programming. To enter into PROGRAM MODE, follow the below steps:

**Step 1:** Keep the selector switch in OFF position



**Step 2:** Press "STOP" key for approximately 4 seconds.



**Step 3:** Press the STOP key on the display of "Program Mode" as shown in the below fig.

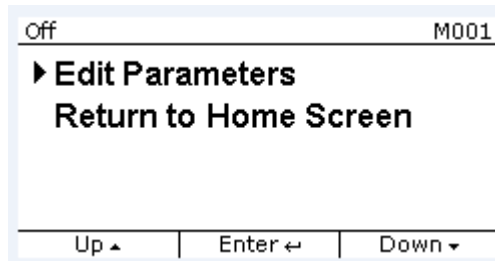

In the program mode, one can choose to configure settings as per customer requirement. The three sub-categories are – **General settings**, **Remote settings** and **Relay settings**. The flowcharts to choose EDIT / VIEW and any one subcategory are given below.

### 4.1.1 EDIT/VIEW option of program mode

By entering the appropriate password, user can enter into the "**PROGRAM MODE**" for 3.XMP Non-Intrusive SIL with Bluetooth Module as shown in the above flowchart. The features that can be set in this are given in the below flowchart.



## PROGRAM MODE AND AUTHENTICATION

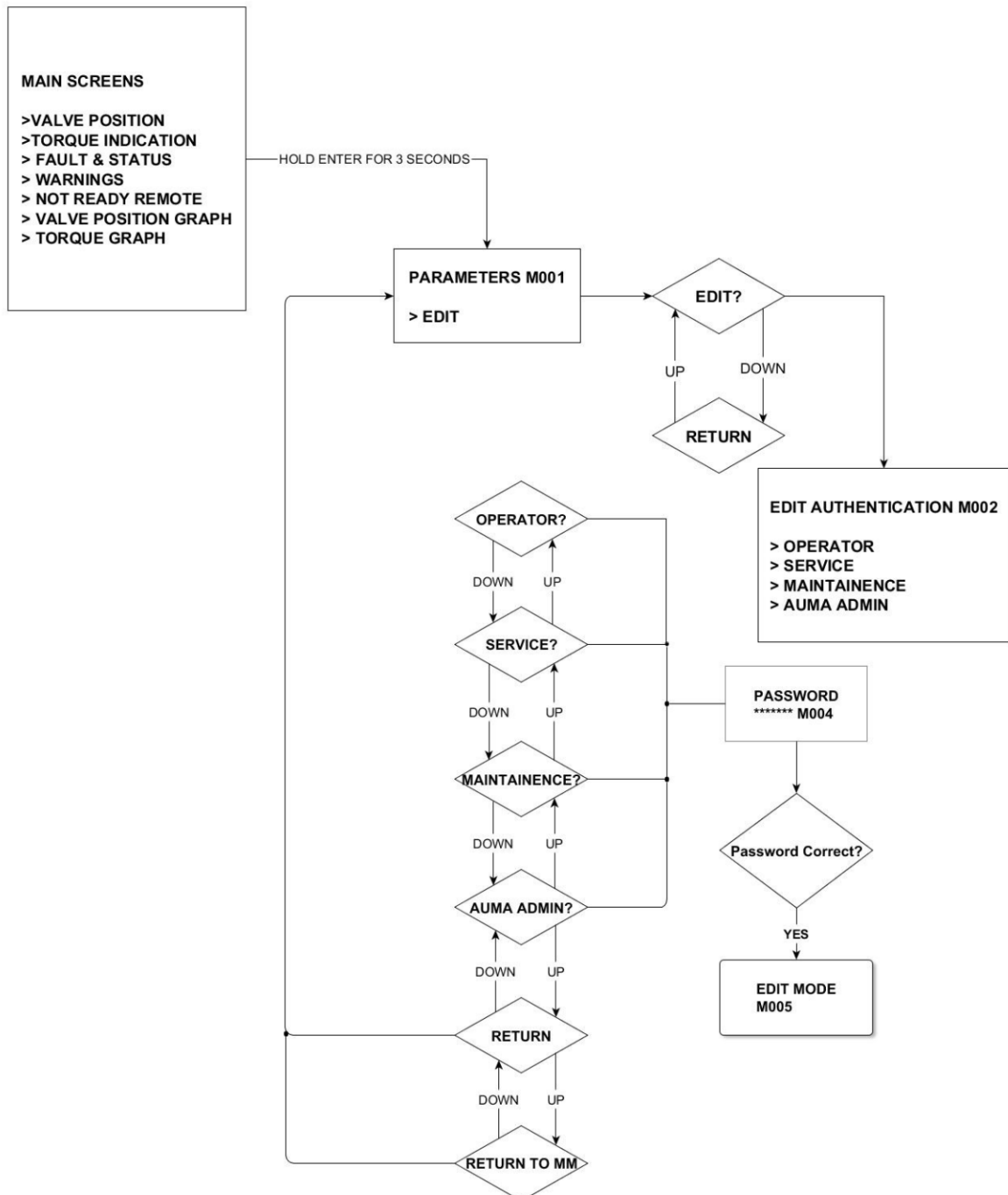

### 4.1.2 EDIT mode parameters

Following options can be set by using the “OPEN” key for navigating up side, “CLOSE” key is for navigating down and “STOP” key is for selecting the parameter in “**ACTUATOR CONTROLS**” of “**PROGRAM MODE**” for 3.XMP Non-Intrusive SIL with Bluetooth actuators.

# DISPLAY PARAMETERS

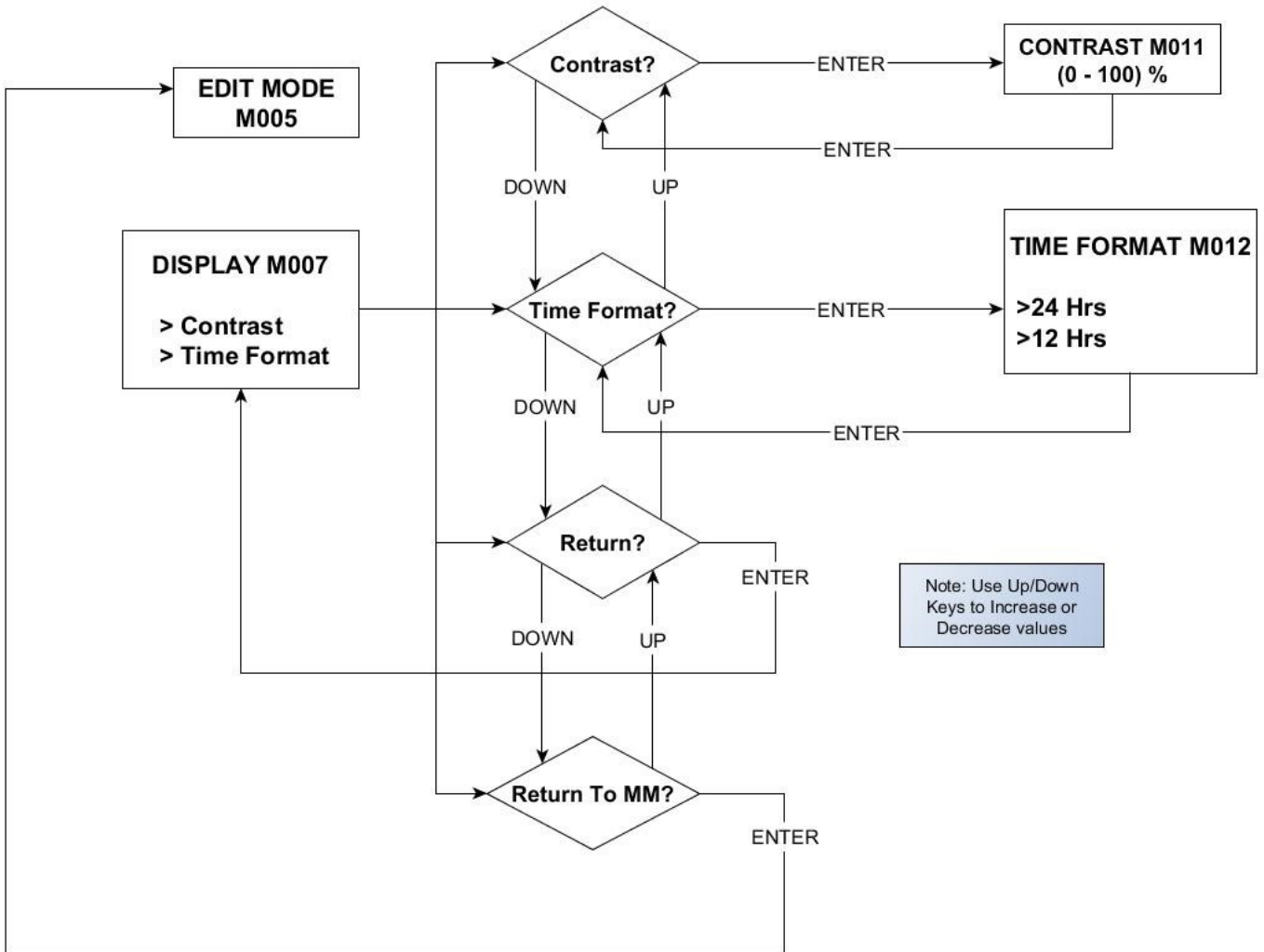

# EDIT MODE PARAMETERS

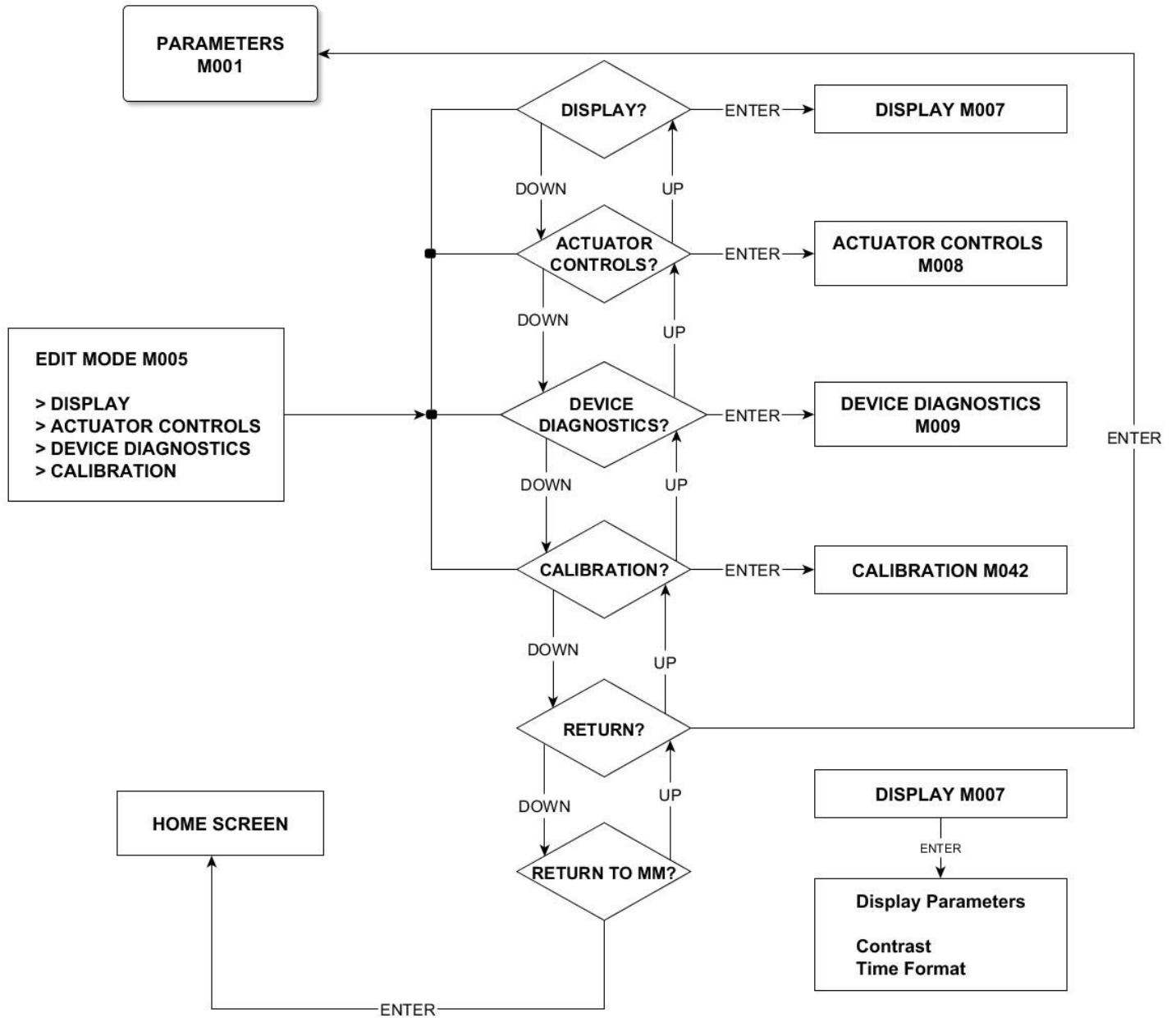

# ACTUATOR CONTROLS

- ACTUATOR CONTROLS M008**

  - >Digital Outputs Configuration
  - >Local Controls
  - >Remote Controls
  - >Band Parameters
  - >ESD Behaviour
  - >PVST
  - >Inhibit
  - >Event Storage
  - >LCS Priority
  - >Local Bypass
  - >Torque Trip Set
  - >Profibus DP
  - >Profibus Configuration

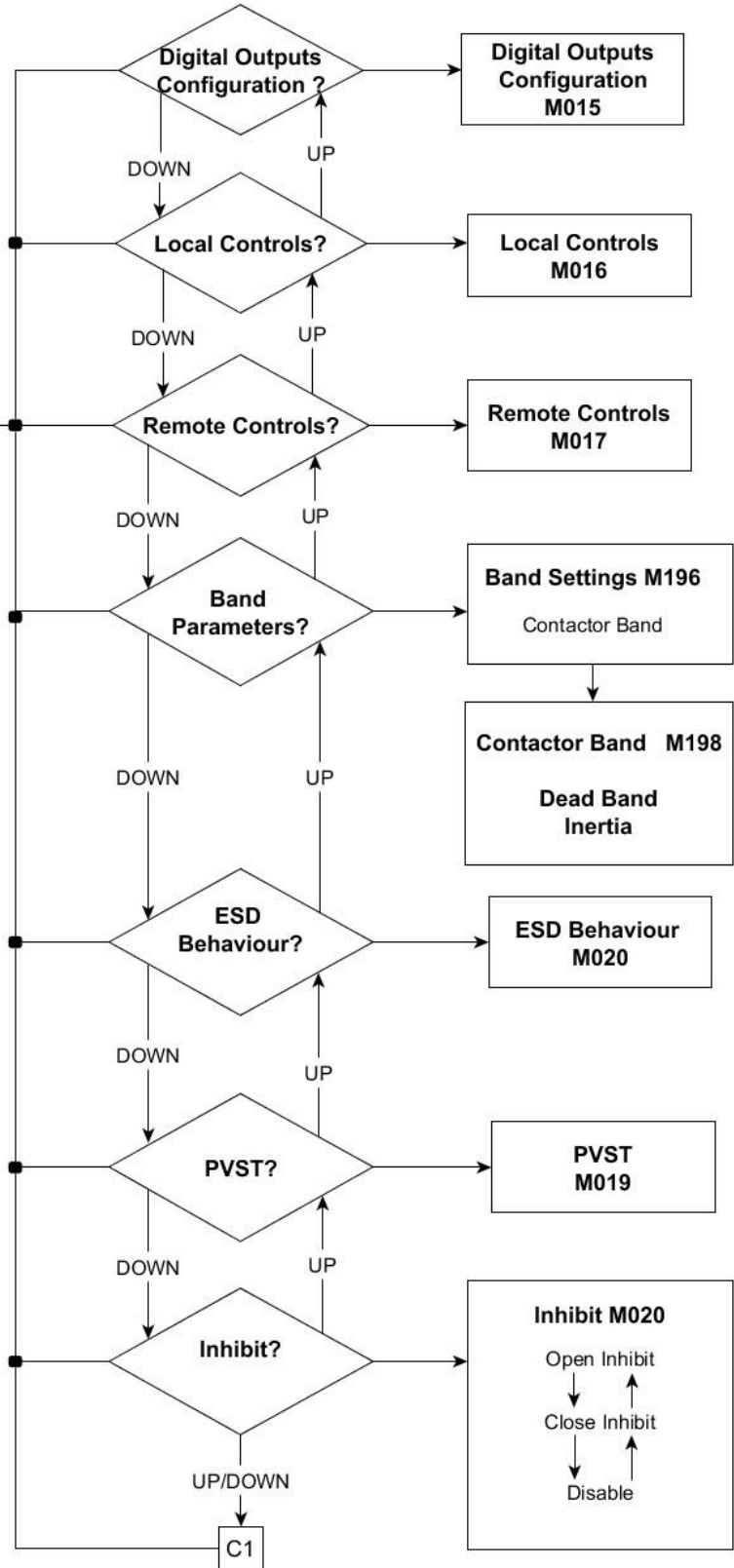

# ACTUATOR CONTROLS

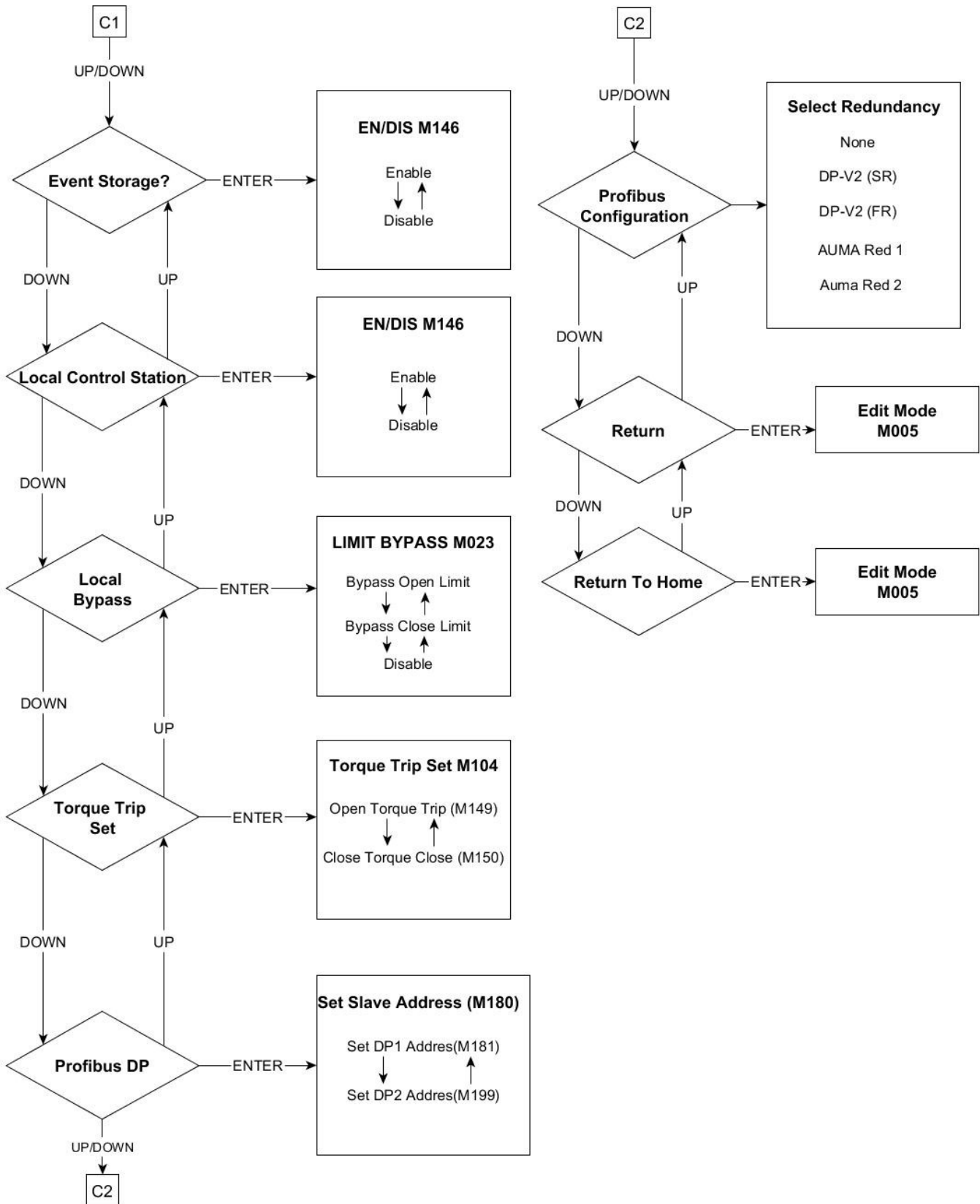

# EMERGENCY BEHAVIOUR

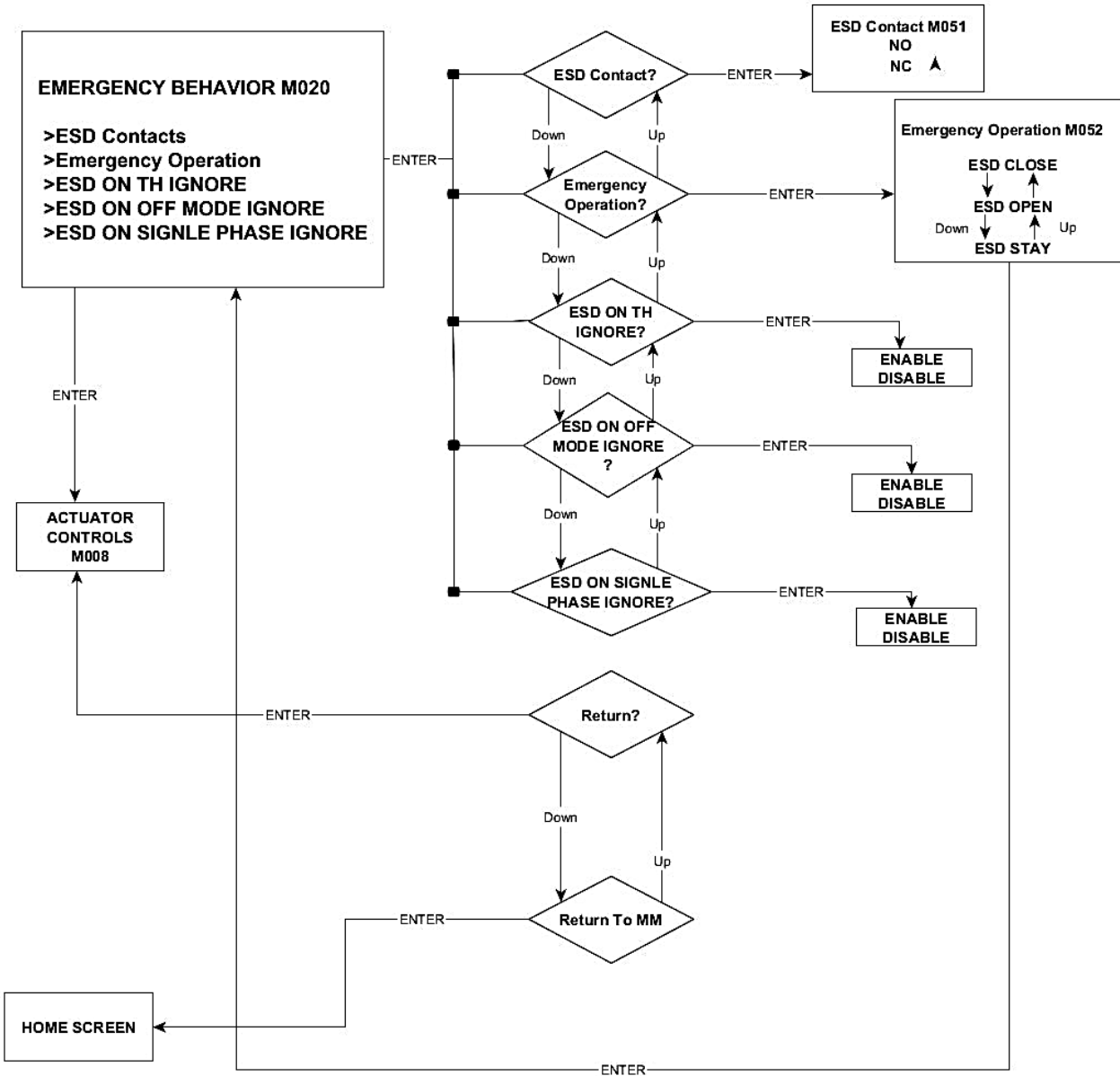

# PARTIAL VALVE STROKE TEST (PVST)

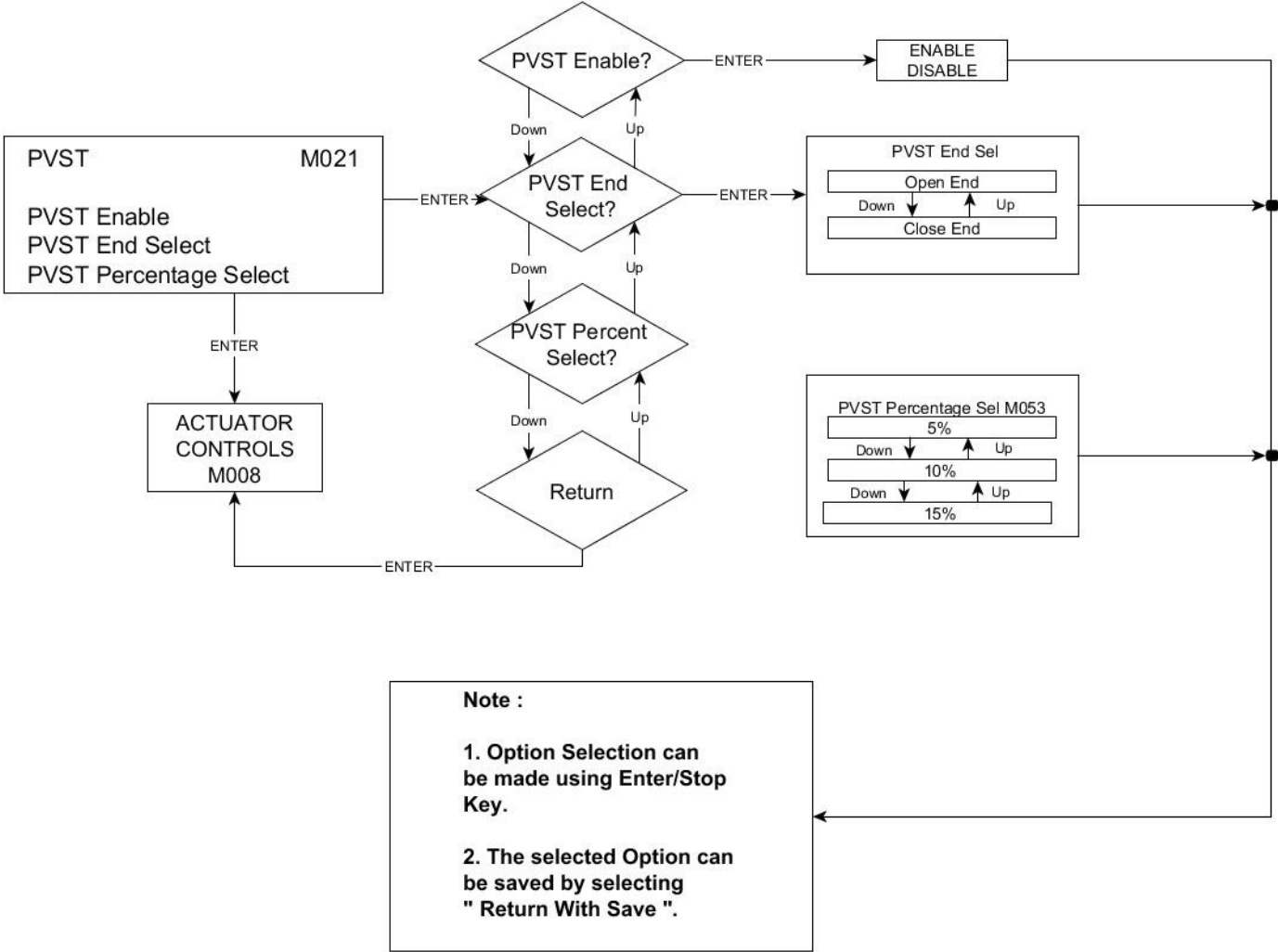

## LOCAL OPERATING MODES

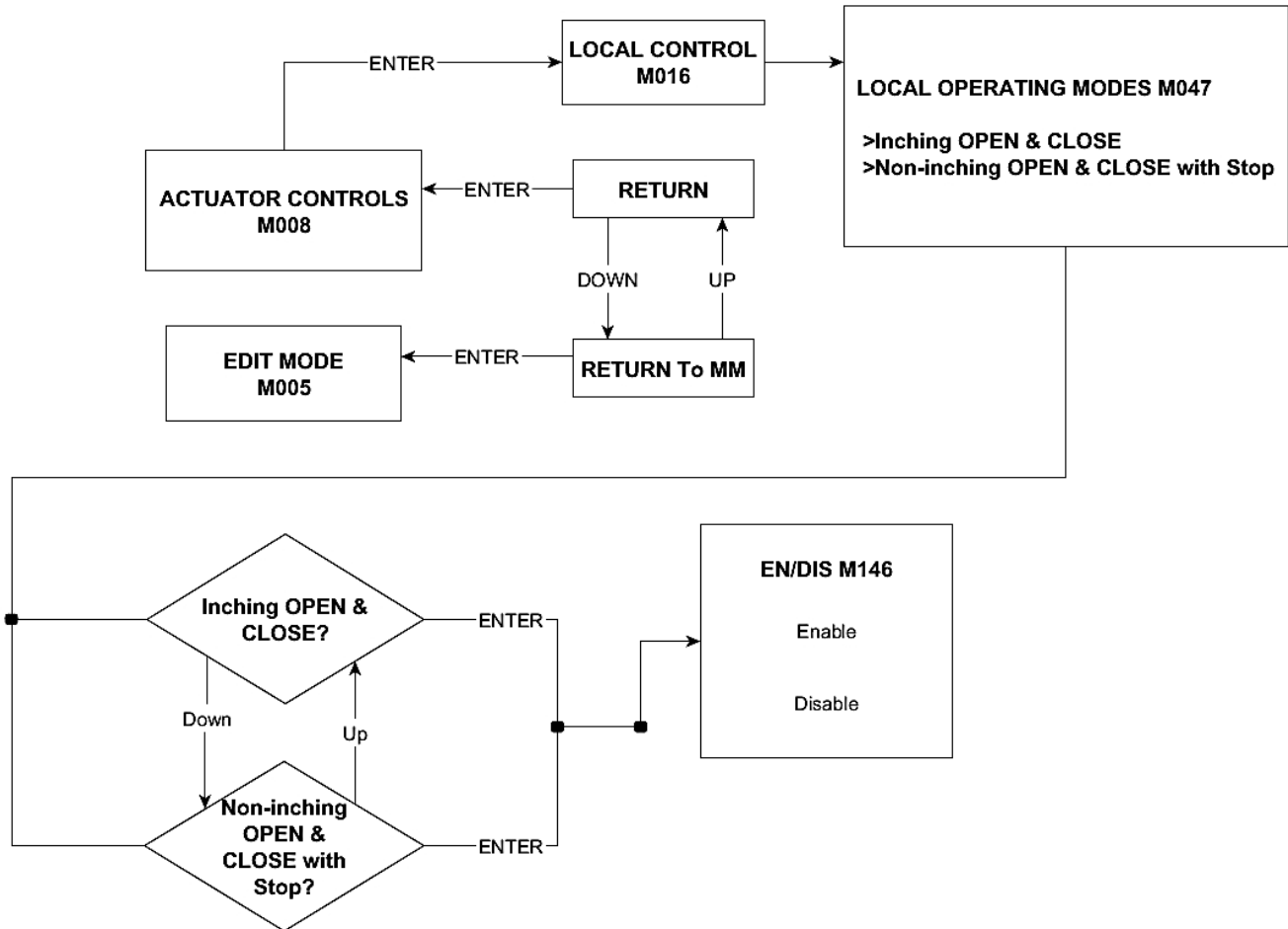

### 4.1.3 Remote settings

The sub options available in this category are shown below.

- I. Selection of remote inching /non inching
- II. 2-wire remote operation: One of the following option will be available with the default/factory setting.
  - 2-wire profibus DP
  - 4-wire
  - 4-wire negative switching

The flowchart for Remote settings is given below.



# REMOTE OPERATING MODES

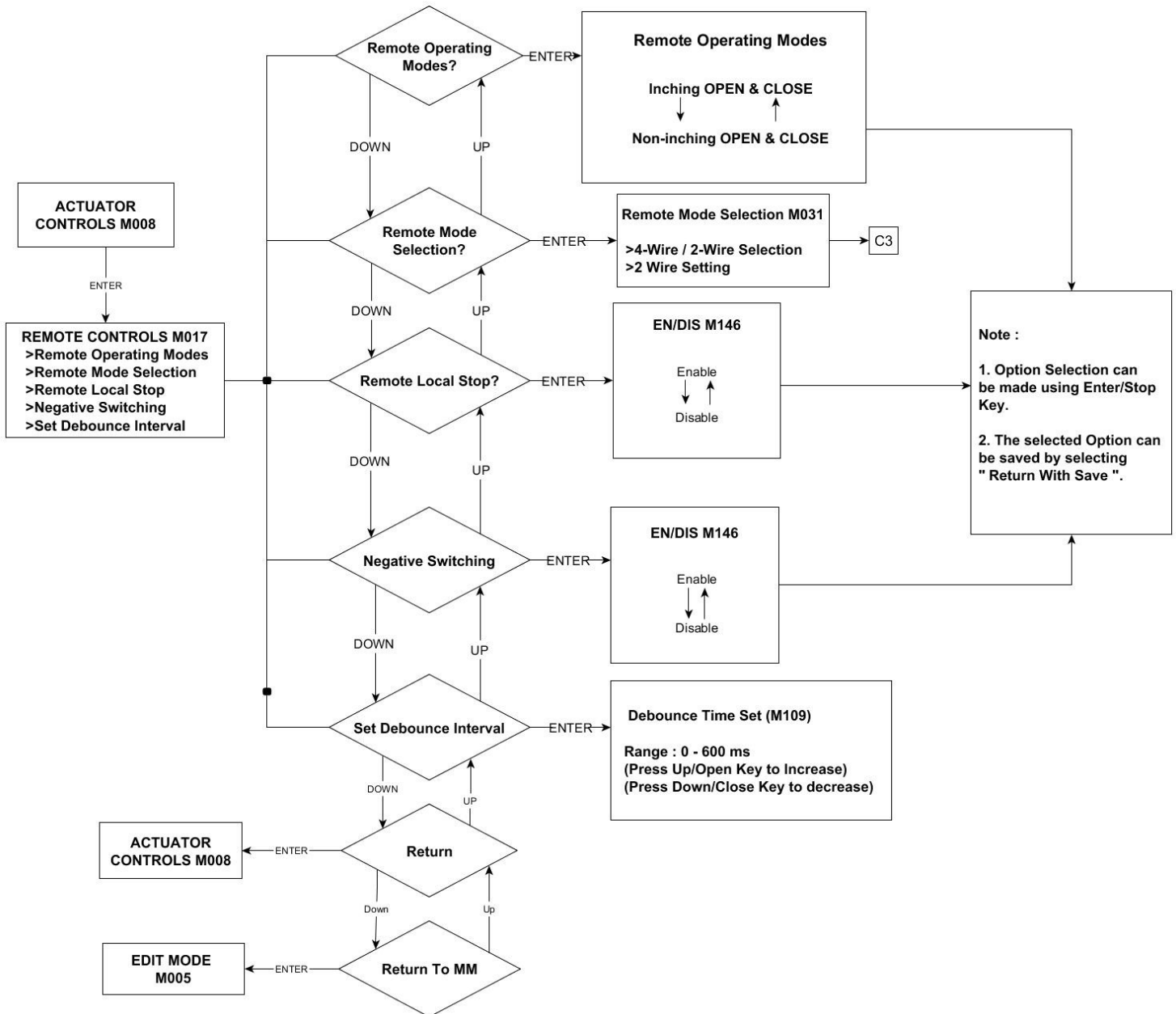

## REMOTE SELECTION

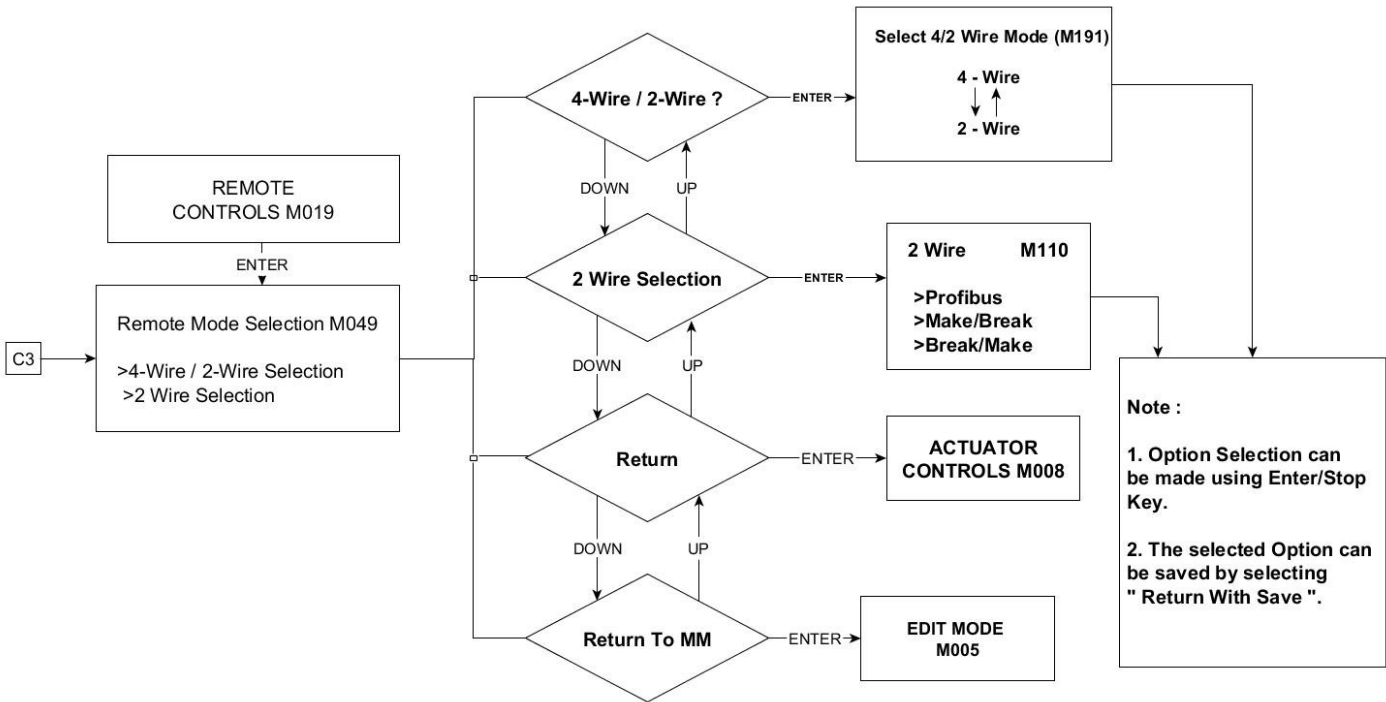

### 4.1.4 Relay Settings

There are two main relays available for setting different faults/ actuator status. These are Fault relay and Optional Relay.

The default configurations for Fault relay are:

1. 24V supply fail Enable /Disable
2. Control supply fail Enable /Disable
3. Single phasing
4. Open Torque Trip
5. Close Torque Trip
6. Jammed Valve
7. Thermal Switch Trip

**Note:** The default configurations for Optional relay are: TOLR Trip

There are about 25 features/ conditions available as shown below which the user can choose set for either of the relays. Note that during the relay setting selection, one or multiple option can be selected for the same relay.

1. Opened (Open Limit Trip)
2. Closed (Close Limit Trip)
3. Remote Local stop
4. Local Stop

5. Open Torque Trip
6. Close Torque Trip
7. Loss of Phase
8. TH-Trip
9. TOLR Trip
10. Control Supply Fail
11. Phase reversal
12. Jammed Valve
13. Power ON
14. Program Mode Indication
15. SP Reached ( via DAC/MODBUS)
16. Selector switch LOCAL
17. Selector switch OFF
18. Selector switch REMOTE
19. ESD Pressed
20. 24V DC Fail
21. Space Heater Fail
22. Running Open
23. Running Close
24. Remote Sel SW EN
25. PVST Fail
26. Intermediate Pos
27. 4-20mA Signal Fail

Note that the Additional Optional Relays and Additional Relays (Four Numbers) can be configured for the same set of faults as shown in the flowchart below. The default settings are off for all of them. These can be configured in Factory Settings in Diagnostic Mode that will be discussed in section 4.2.

# DIGITAL OUTPUT CONFIGURATION

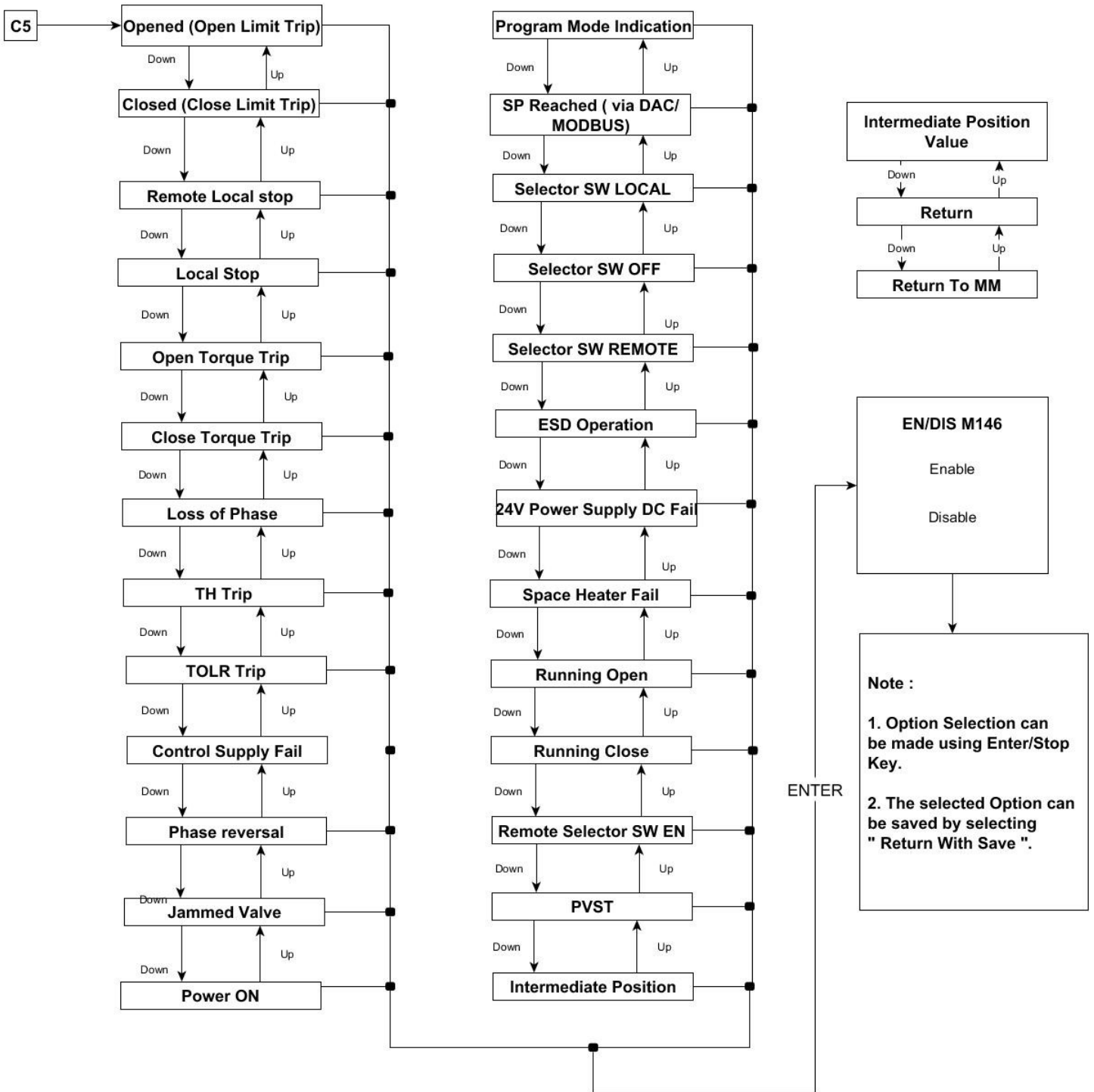

### 4.1.5 Intermediate Position Setting

This setting is used to operate a relay to indicate the intermediate valve position. After entering "Intermediate Pos" from other options you can select the position from 1 to 99 and press stop to save. Any of the relays can be configured to show this position. The relay can be configured from relay settings mentioned above.

## DIGITAL OUTPUT CONFIGURATION

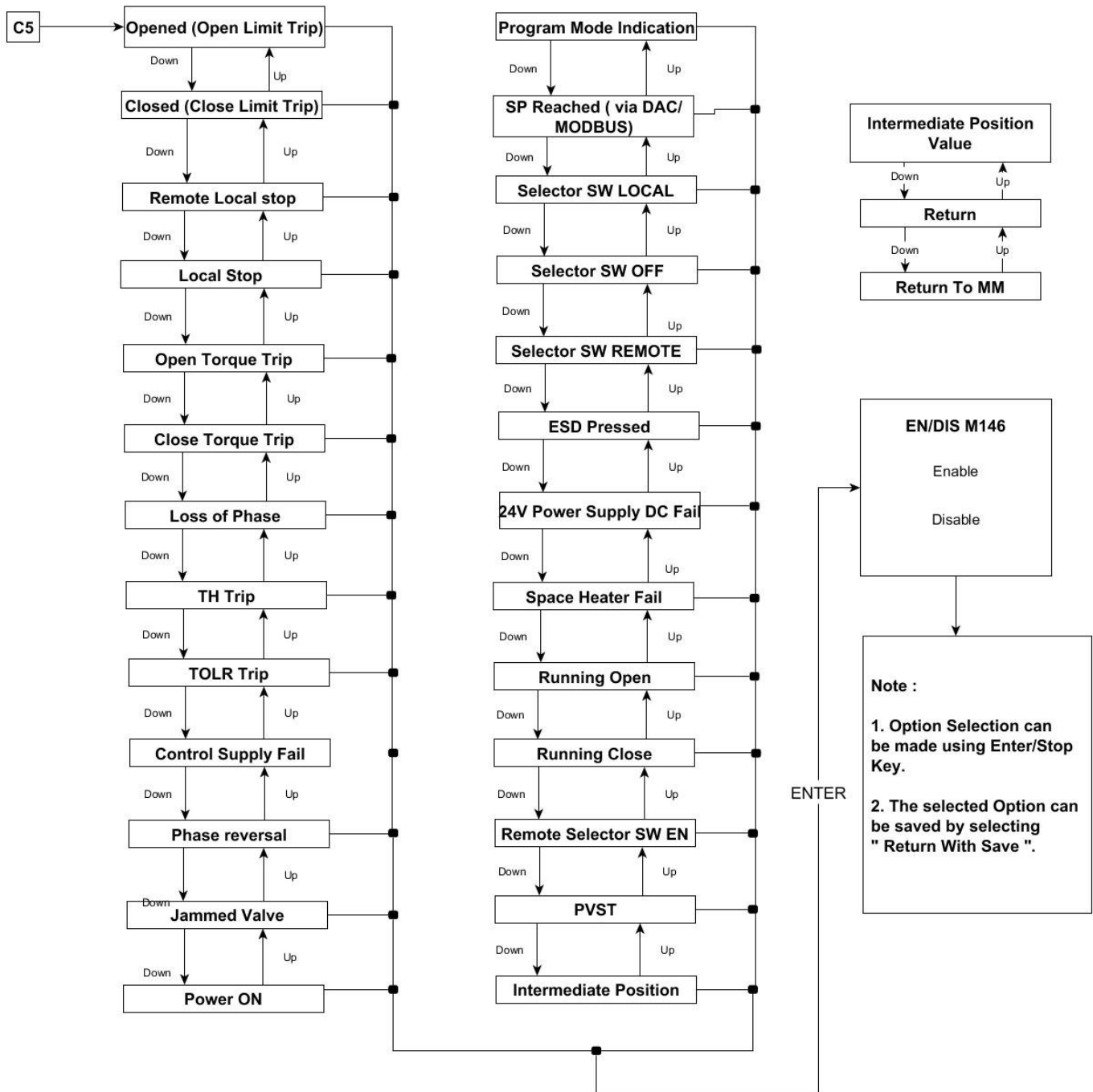

## 4.2 Diagnostic mode

This mode is used to mainly diagnose the control module and its configurations. This device diagnostic option can be used to see the Device information, Bluetooth information, Absolute encoder value, RTC settings, MWG and profibus CAN details, Profibus details, Factory reset, Thermal proof test as shown in the below flow chart to Enter Diagnostic Mode press "STOP " key for approximately 3 seconds when the actuator is in the off mode as shown below.

**Step 1:** Keep the selector switch in OFF position



**Step 2:** Press "STOP" keys (together) approximately 3 seconds



**Step 3:** Press the STOP key on the display of "Diagnostic Mode" as shown below.

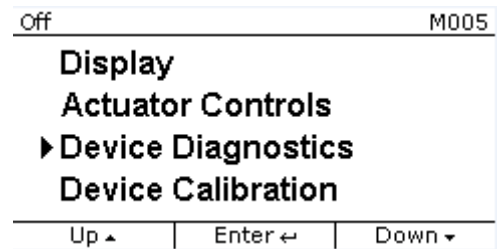

From Diagnostic mode you can get the following values: The software version installed, the raw RTC and POT values etc. can be checked here. One can give commands and check if these values increase/decrease accordingly. The RTC reading can be verified and checked if it is correct. A factory reset to set the system into default settings according to the customer specifications can be carried out. Besides this, there is an option of Factory settings in the module only under the scope of AUMA India service engineer that has several software configurable options.

# DEVICE DIAGNOSTICS

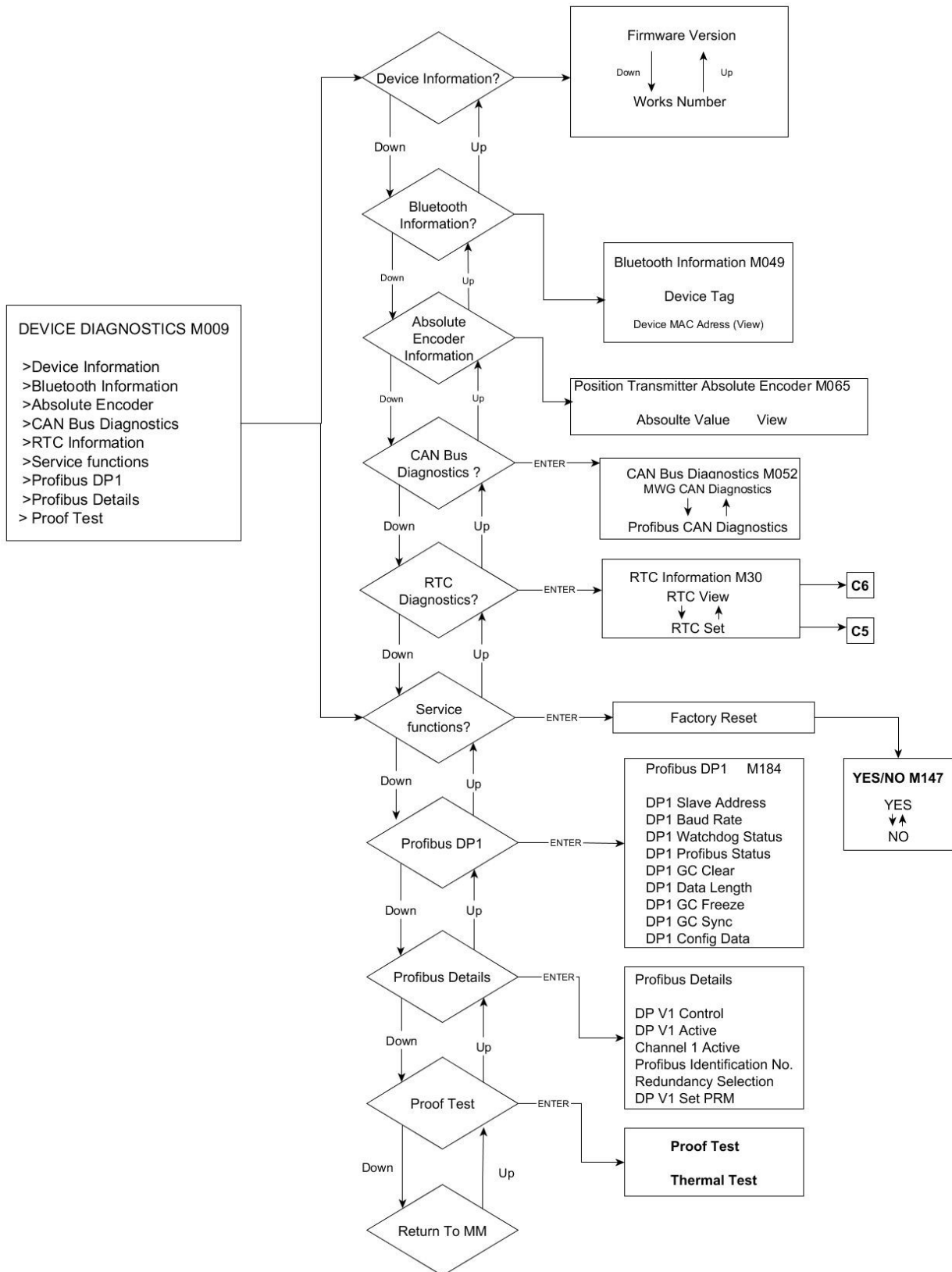

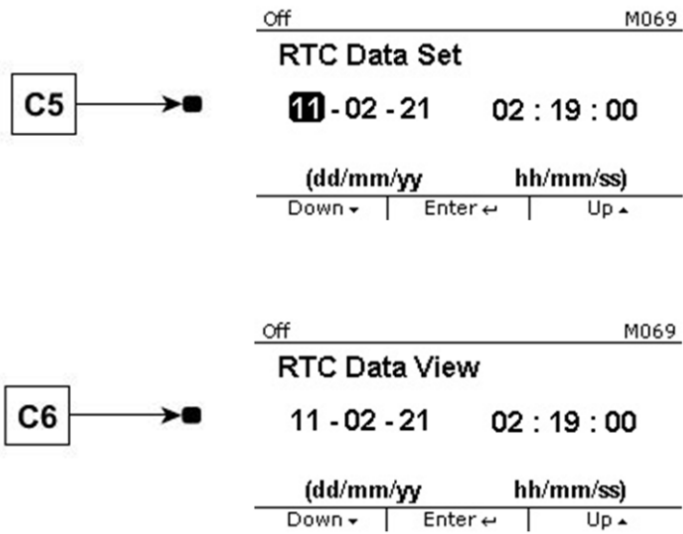

### 4.3 Calibration mode

In this mode, the following three key parameters can be calibrated:

- I. Limit Calibration for MWG

To enter into the Calibration Mode follow the below steps:

**Step 1:** Keep the selector switch in OFF position



**Step 2:** Press " STOP" keys approximately 3 seconds



**Step 3:** Put suitable password to go further

**Step 4 :** Select "Device Calibration" as shown in the below screen

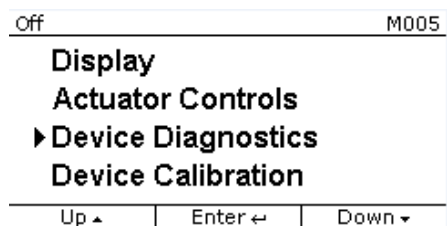

The below flowchart depicts how to enter into different calibration modes. For clear understanding of all.

Options of CALIBRATION MODE, refer to the detailed flowcharts presented in the following sections.



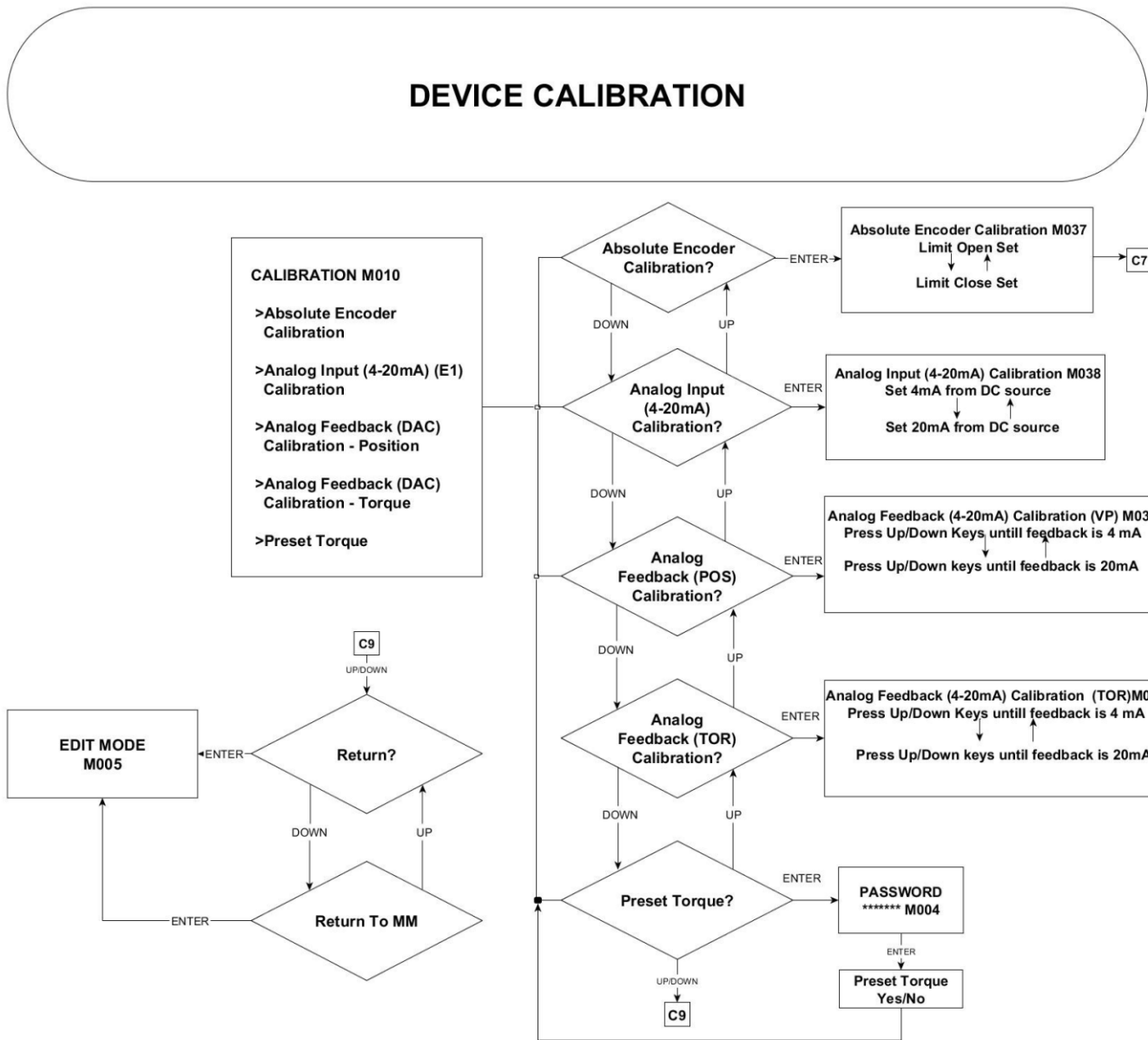

### 4.3.1 Limit open calibration

- a. The LCD screen shows the current value of Open Limit.



- b. Press OPEN push button to run the actuator in Open direction. Press "STOP" button to stop the actuator before reaching end travel.
- c. Engage Manual operation. Turn the hand wheel until valve is completely Opened.
- d. Confirm the calibration by giving "yes" by pressing "OPEN" key and " STOP" to store.
- e. Press STOP key to accept the Open Limit Value.
- f. Follow the flow chart mentioned below.

**4.3.2 Limit close calibration**

- a. The LCD screen shows the current value Close Limit.

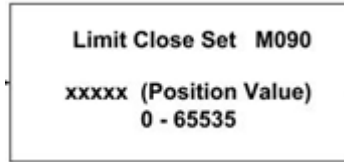

- b. Press CLOSE push button to run the actuator in Close direction. Press "STOP" button to stop the actuator before reaching end travel.
- c. Engage Manual operation, Turn the hand wheel until valve is completely Closed.
- d. Confirm the calibration by giving "yes" by pressing "OPEN" key and " STOP" to store.
- e. Press STOP key to accept the Close Limit Value.
- f. Follow the flow chart mentioned below.

**LIMIT CALIBRATION**

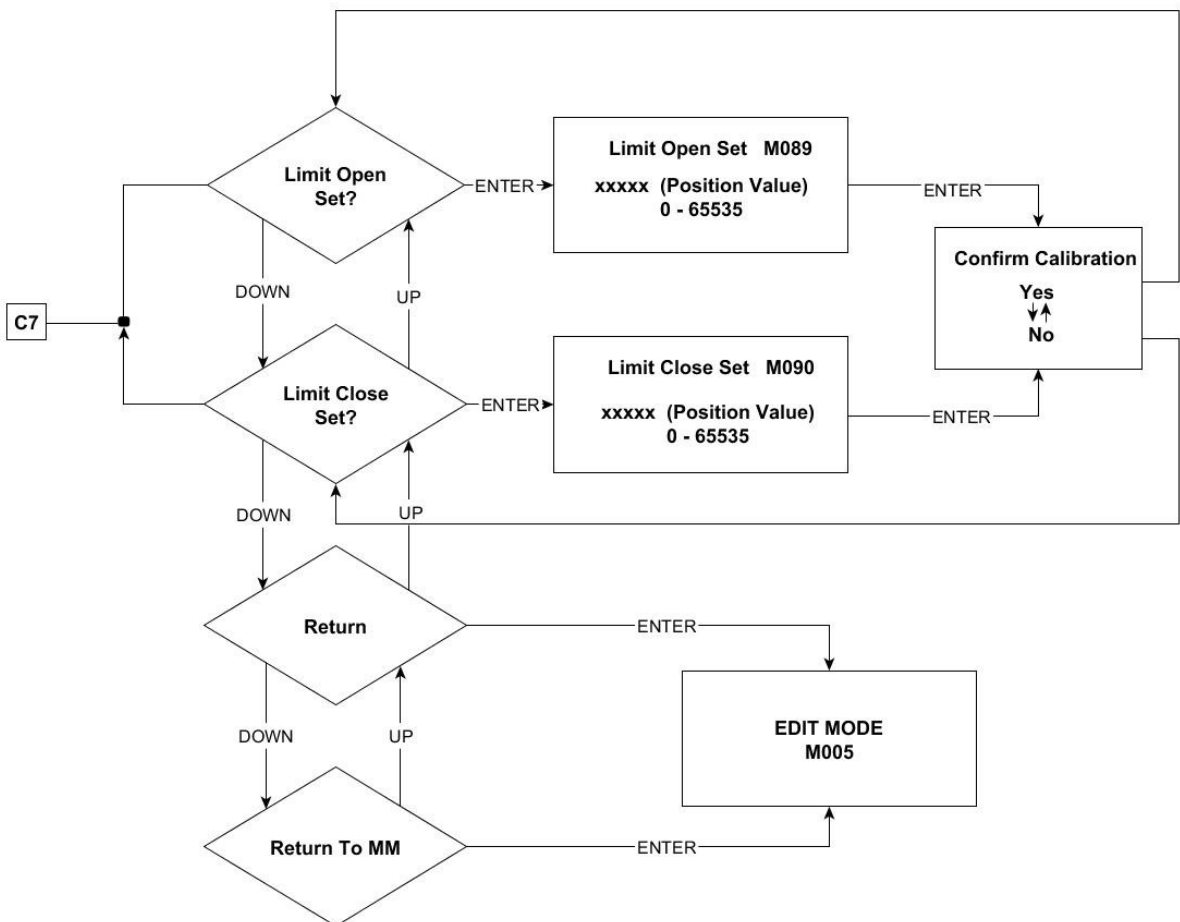

### 4.3.3 Close limit and Open limit calibration through counter gears/ limit switches

After calibration of limit through MWG.2, CLOSE limit and OPEN limit to be calibrated inline with MWG,2 and make sure the CLOSE limit trip and OPEN limit trip happens through counter gears and limit switches inline with MWG.2.

Please follow below steps for CLOSE limit and OPEN limit calibration through counter gears and limit switches.

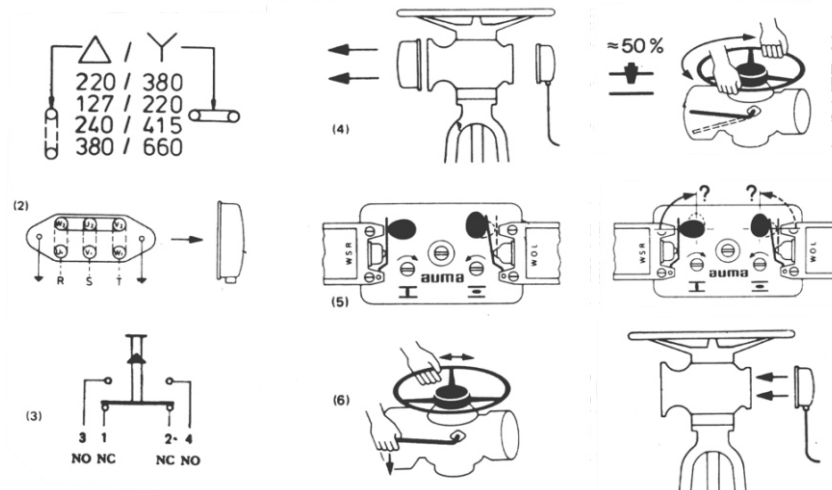

#### 1. Electric connection

For 3 phase AC - motors:

Check whether terminal links are fitted to suit type of motor and power supply (fig.1).

Connect wires R-S-T to terminal pins U1-V1-W1 (fig. 2), for flame proof enclosure at clip-on terminals.

For single - phase or DC - motors, see instructions in terminal compartment. Connect control wires according to the wiring diagram.

Terminal plan is inside the terminal compartment.

Note : The two circuits of each switch (fig. 3) are suitable only for the same potential.

#### 2. Remove cover at switch compartment (fig.4) Check whether limit-switch has tripped (fig.5) Valve completely closed : WSR tripped Valve completely opened : WOL tripped

#### 3. Engage manual drive :

Push declutch lever as indicated by arrow (fig. 6). If resistance is felt, turn handwheel slowly while lever is pressed till manual drive engages.

#### 4. Operate valve to intermediate position manually (fig. 7)

Direction OPEN ( ) turn handwheel anti-clockwise. Direction CLOSED ( ) turn handwheel clockwise. Switch cam at (Z) or (O) should rotate 90° and release the switch (fig. 8) if set properly.

#### 5. Ensure sealing faces at control plug are clean and check whether O-ring is ok. Apply thin film of non - acid grease to sealing faces, then replace plug cover (fig. 9)

#### 6. Connect to mains. Switch on motor momentarily. Manual drive will be disengaged automatically.

#### 7. Check direction of rotation (fig. 10), observing arrows at limit switch counter gear (fig.11). If incorrect, stop immediately and change sense of rotation (if 3 phase AC-motor, exchange any two phases)..

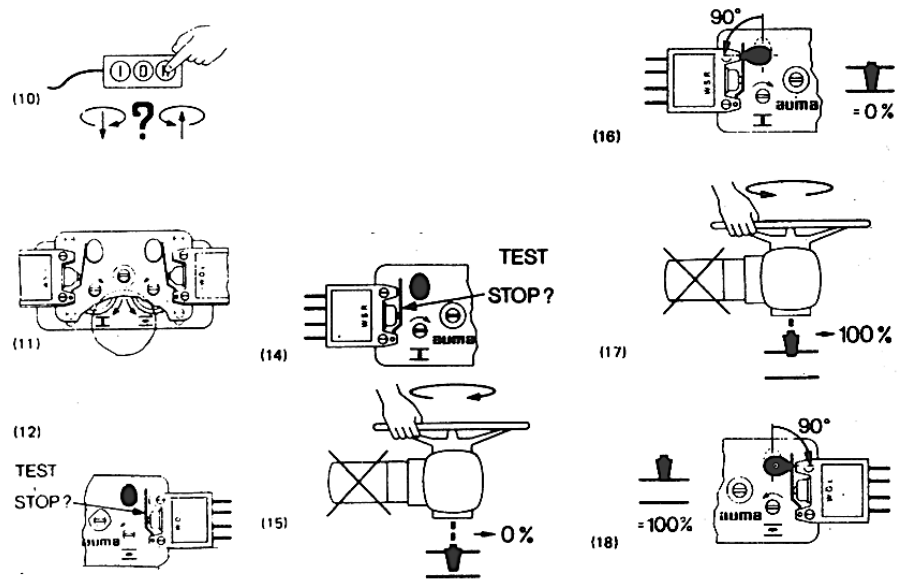

8. Start actuator in OPEN direction and switch off by manually tripping limit switch WOL (fig. 12).
9. For position seated closing: Start actuator in CLOSED direction and switch off by manually tripping limit switch WSR (fig. 14).
10. If actuator does not stop, check connection of terminals and the control wiring.
11. Determine over-run of actuator in both directions by visual inspection (amount of additional rotation of spindle or valve movement after actuator is switched off ).
12. Engage manual drive and operate actuator to fully closed position (fig. 15), while observing the switch cam for limit switch WSR.  
For position seating: When the switch has tripped (fig. 16) continue turning handwheel to the final position and check whether the remaining travel corresponds to the over-run. If not, reset to suit. See point 14.
13. Operate actuator manually to OPEN-position (fig. 17). Check in the same way as described above for position seating, see point 12 (fig. 18).

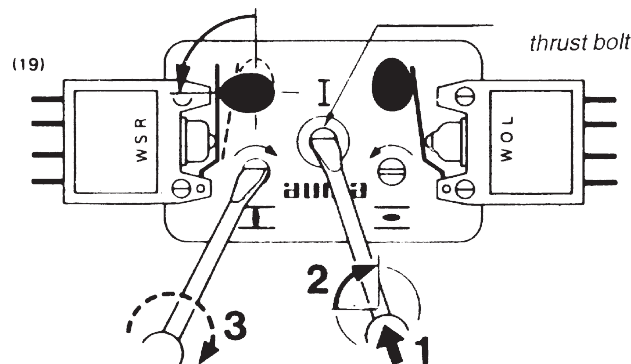

14. Resetting limit-switching:
  - Operate valve away from end-position to account for over-run or to the desired switch tripping point.
  - Push thrust bolt I inwards and turn (fig. 19). The bolt remains in this position.
  - For CLOSED position turn spindle marked **I**(Z), (for OPEN position spindle marked **≡**, O) slowly as indicated by arrow (fig. 19). Distinct "clicks" can be felt and heard. Continue turning the spindle until the cam operates the switch. At this stage, the spindle should not "click" any more and should not be turned any further.

If inadvertently you override the tripping point, continue turning the spindle slowly in the same direction till the switch cam goes back to its original position. Repeat setting instructions as above described.

- Turn thrust bolt I till it snaps back into its original position by spring action.
- 15. Immediately after start-up : Ensure sealing faces at cover and housing are clean. Check whether O-ring is correctly in position and apply a thin film of non-acid grease. Replace the cover and fasten with 4 screws.
- 16. Fasten control cover screws and tighten glands at conduit entries.

#### 4.3.4 Setting of Mechanical position indicator

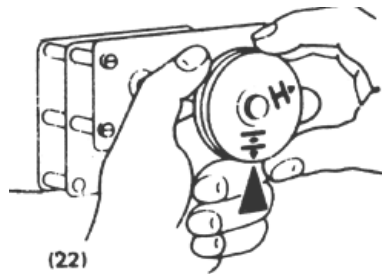

The two dials have a slip clutch for easy adjustment. At valve fully closed, turn dial (CLOSED) till the arrow is in alignment with the mark **II** on the show glass. Operate valve into fully OPEN position and adjust dial marked **III** (OPEN) till the arrow mark is in alignment with the mark on the cover.

Note: The dial (CLOSED) must be held in position while adjusting dial (OPEN) (fig. 22).

#### 4.3.5 Do's and Don'ts - Troubleshooting tips

**Setting of Limit switches:**  Improper methods of declutch mechanism leading to premature failure of tripping arm.



 Improper tightening of covers or missing of o-rings during fitment.

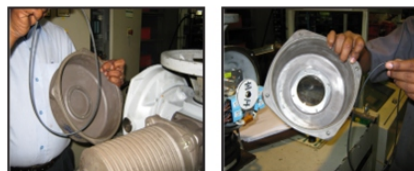

 In the events of interchangeability check for the e-pac wiring diagram number.

 Do not press mechanical interlock of reversing contactors manually.

#### Additional Tips

- Do not operate the actuator with improper wiring.
- Do not interchange the cards without checking the e-pac code.
- Do not interchange the e-pac without checking the TOLR rating.
- Improper sealing of cable glands resulting in water entry at site inadvertently damaging all the electronic cards.

- Do not operate the actuator in manual mode while electrically operating.
- Please check the input voltage rating of the motor before giving supply.
- Do not run the NORM actuator without panel.
- Do not bypass the thermoswitch connection in the loop

**I** All AUMA actuators are 100% tested and factory checked. Actuators are supplied ready for service. Most of the actuators are supplied to valve manufacturers for mounting to valves. It is usual for the valve manufacturer to set the switches and test the motorized valve.

**Special care should be taken when commissioning.**

Wrong connection or faulty control wiring may result in damage to the motorized valve.

In case the actuators will not be mounted or commissioned for a long period, take care for adequate (dry) storage, refer to our instruction sheet "Transport, Storage and Commissioning of AUMA - actuators"

**4.3.6 Change torque trip value**

Change torque trip value can be changed by using below mentioned flow chart and this flow chat has been derived from "Actuator control flow chart".

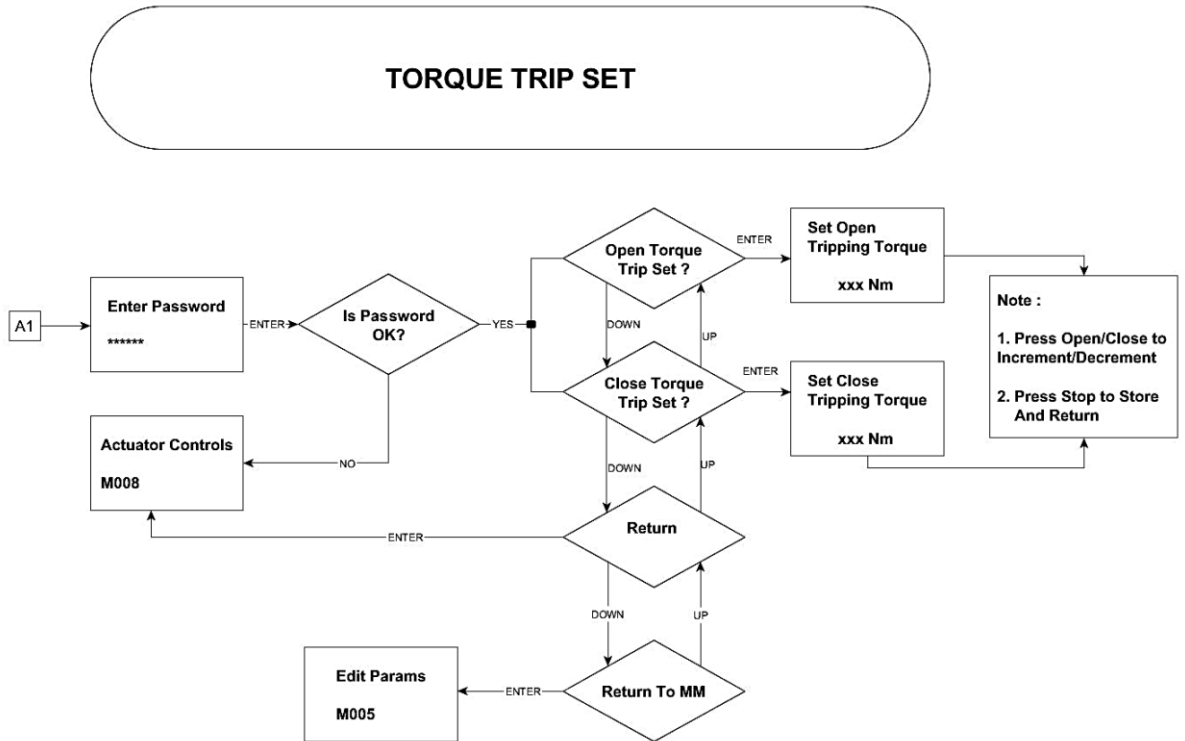

**4.3.7 Preset torque**

Preset torque can be done by referring "Device calibration" flow chart

**5 Annexure**

Wiring Diagrams for SIL with Profibus DP  
Wiring Diagrams for SIL without Profibus DP  
SIL certificate

Wiring Diagram for SIL with Profibus DP

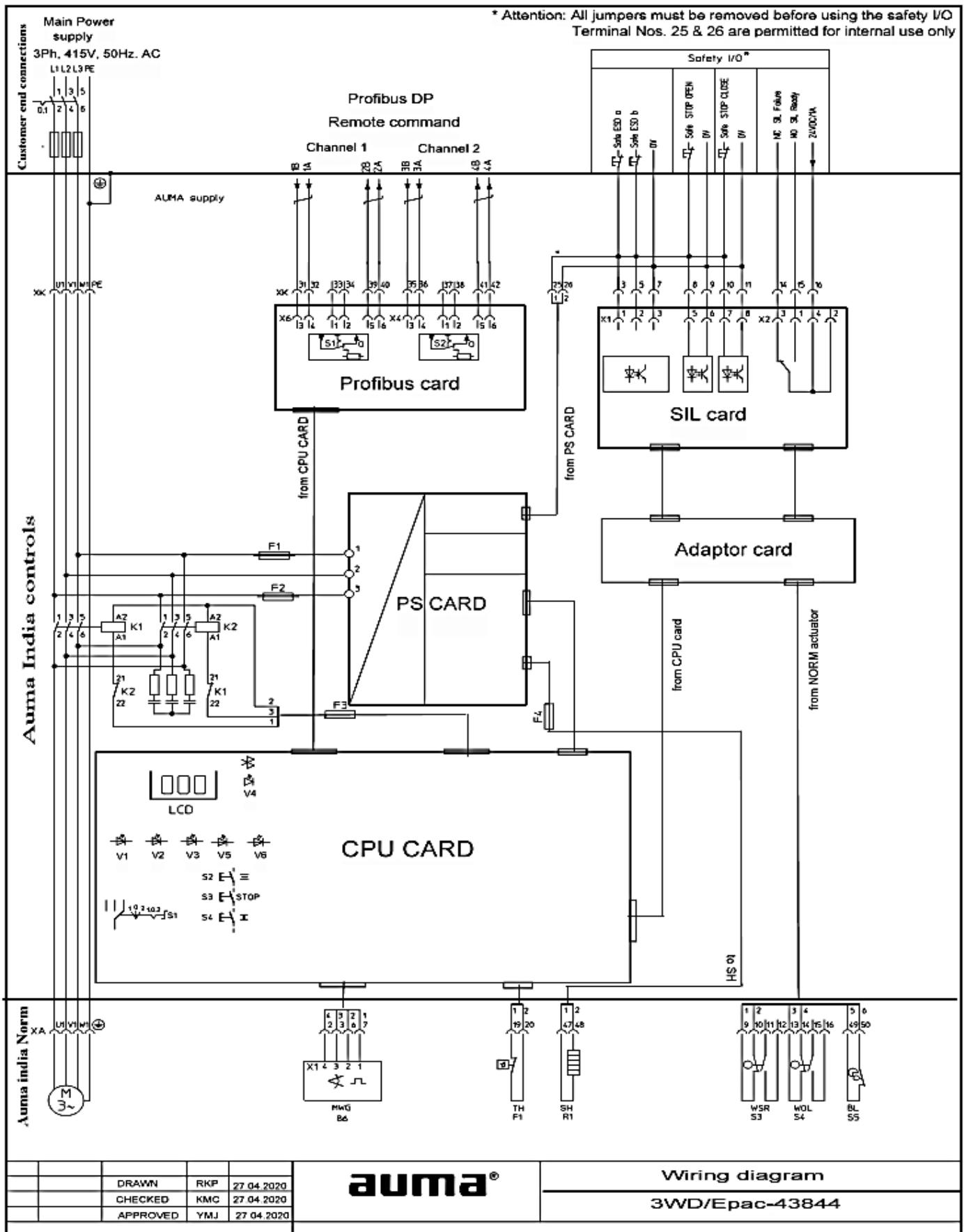



Wiring Diagram for SIL with Profibus DP

**Legend for Customer end connection as per Terminal Nos. wise description:-**

**XK** -Terminals for customer's connection  
**U1, V1, W1, PE (L1, L2, L3, E)** -Main power supply (3Ph, 415V, 50Hz. AC)  
 Profibus command from customer's DCS for remote operation: (Refer terminals 1A, 1B, 2A, 2B, 3A, 3B, 4A & 4B for Profibus connections)  
**Channel - 1**                      **Channel - 2**  
**IN: 1A, 1B**                      **IN: 3A, 3B**  
**OUT: 2A, 2B**                      **OUT: 4A, 4B**  
**SIL command from customer's DCS & SIL feedback to customer's DCS:** (Refer terminals 3 to 16 for SIL I/O connections)  
 Safety I/O  
 Safe ESD a  
 Safe ESD b  
 Safe stop OPEN  
 Safe stop CLOSE  
 Safe SIL failure / ready

**Legend for Auma india controls:-**

**CPU CARD**      CPU Card includes control board, logic board and Local control board  
**Local controls**  
**S1**              Selector switch LOCAL - OFF - REMOTE  
**S2**              Push button OPEN  
**S3**              Push button STOP  
**S4**              Push button CLOSE  
**V1**              Indication light for End position - close  
**V2**              Indication light for Common fault  
**V3**              Indication light for End position - open  
**V4**              Bluetooth  
**V5**              Indication light for over torque operated - close  
**V6**              Indication light for over torque operated - open  
**Display type:**      LCD type display for plain text display of Actuator information (Status & fault indication), Setting and calibration  
**S1**              Selector switch for Local-Off-Remote selection  
**PS CARD**      Power supply card includes Transformer and output Relays  
**F1 & F2**          Primary fuses for power supply (mounded separately on mounting plate)  
**F3**              Secondary fuse for Control supply (mounded separately on mounting plate)  
**F4**              Secondary fuse for Space heater (mounded separately on mounting plate)  
**Profibus**      Profibus card for Remote command  
**SIL**              SIL card for Safety I/O command / feedback  
**Adaptor**      Adaptor card for connection between norm actuator switches & SIL card  
**K1 & K2**      Reversing contactor for open & close operation

**Legend for Norm Actuator:-**

**XA**              - Terminal connection at NORM actuator side (50 Pin plug in circular connector)  
**M**                - 3Ph AC motor  
**MWG B6**      - Absolute encoder for limit (position) & over torque operation  
**S3 WSR**      - Limit switch, closing, clockwise rotation  
**S4 WOL**      - Limit switch, opening, counterclockwise rotation  
**S5 BL**        - Blinker transmitter  
**F1 TH**        - Thermo switches  
**R1 SH**        - Space heater in switch compartment

				<b>auma®</b>	Wiring diagram
	DRAWN	RKP	27.04.2020		3WD/Epac-43844
	CHECKED	KMC	27.04.2020		
	APPROVED	YMJ	27.04.2020		

Wiring Diagram for SIL without Profibus DP

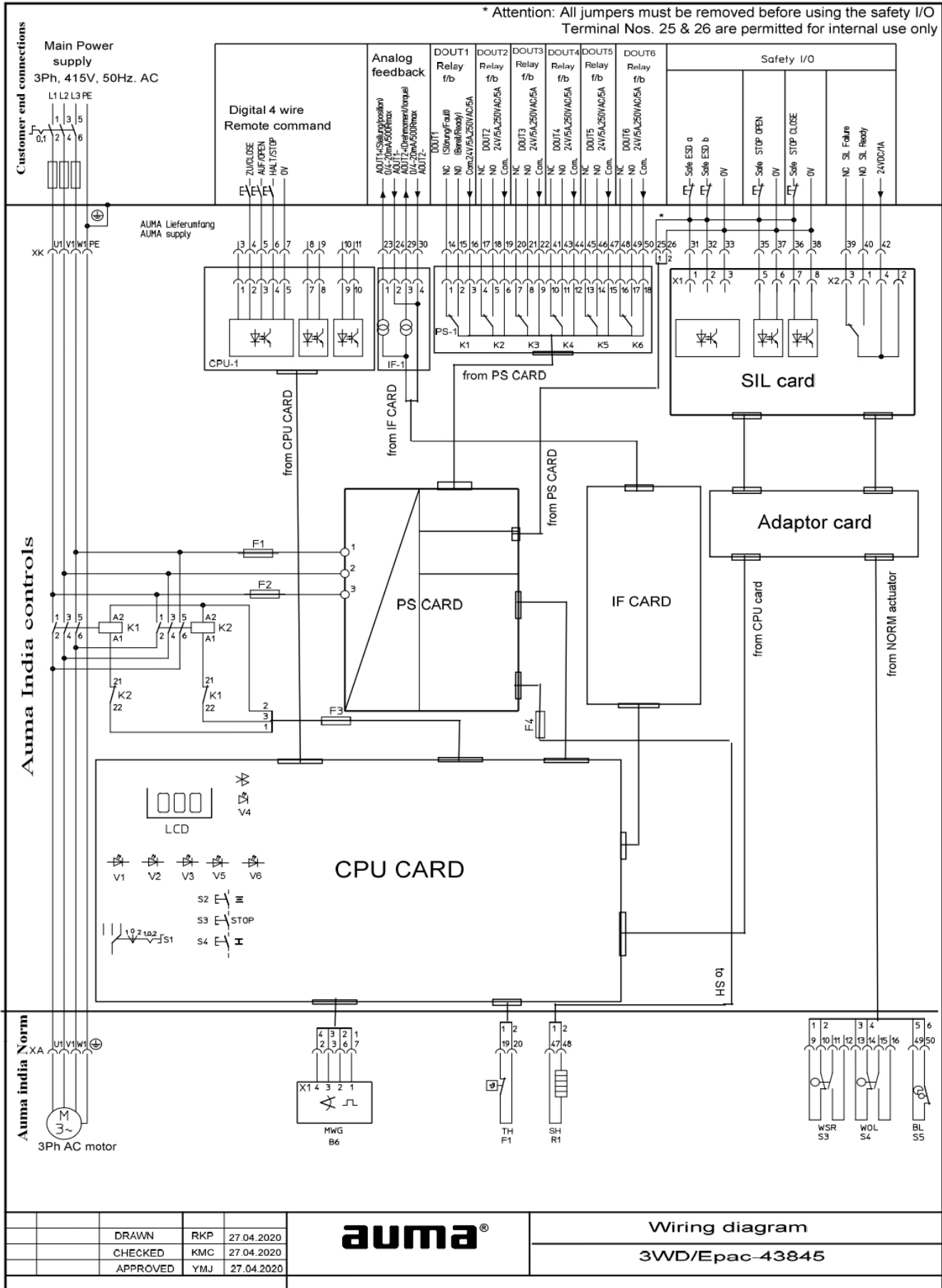

DRAWN	RKP	27.04.2020
CHECKED	KMC	27.04.2020
APPROVED	YMJ	27.04.2020

**auma**

Wiring diagram  
3WD/Epac-43845

Wiring Diagram for SIL without Profibus DP

**Legend for Customer end connection as per Terminal Nos. wise description:-**

XK -Terminals for customer's conncion  
 U1, V1, W1, PE (L1, L2, L3, E) -Main power supply (3Ph, 415V, 50Hz. AC)

**Command signal from Customer's DCS (Customer's 24V sed for following commands):-**  
 Terminal Nos. 4 & 7 - Remote Close command (Potential free contacts to DCS)  
 Terminal Nos.5 & 7 - Remote Open command (Potential free contacts to DCS)  
 Terminal Nos. 6 & 7 - Remote Stop command (Potential free contacts to DCS)

**Analog feedback to Customer's DCS:-**  
 Terminal Nos. 23 & 24 - Position feedback (Analog output 4-20mA) to Customer's DCS  
 Terminal Nos. 29 & 30 - Torque feedback (Analog output 4-20mA) to Customer's DCS

**Potential free contacts (Relay feedback) to Customer's DCS:-**  
 Terminal Nos. 14 & 16 (DOUT1) - Collective fault signal ("NC"-contact)  
 (This "NC" contact becomes "NO" contact during following faulty condition)  
 Torque fault, Phase failure, Motor protection tripped  
 Terminal Nos. 15 & 16 (DOUT1) - Actuator in Healthy indication ("NO"-contact) / (Indication for ready to start)  
 (This "NO" contact becomes "NC" contact during above faulty condition)

**The following Relays can be programmed as required Potential free contacts (Relay feedback) to Custome**  
 Terminal Nos. 17-19 (NC) & 18-19 (NO) / DOUT2: Close status  
 Terminal Nos. 20-22 (NC) & 21-22 (NO) / DOUT3: Open status  
 Terminal Nos. 41-44 (NC) & 43-44 (NO) / DOUT4: Selector switch in Remote mode  
 Terminal Nos. 45-47 (NC) & 46-47 (NO) / DOUT5: Torque close trip  
 Terminal Nos. 48-50 (NC) & 49-50 (NO) / DOUT6: Torque open trip

SIL command from customer's DCS & SIL feedback to customer's DCS: (Refer terminals 31 to 42 for SIL I/O connections)  
 Safety I/O  
 Safe ESD a  
 Safe ESD b  
 Safe stop OPEN  
 Safe stop CLOSE  
 Safe SIL failure / ready

**Legend for Auma india controls:-**

**CPU CARD** CPU Card includes control board, logic board and Local control board  
**Local controls**  
 S1 Selector switch LOCAL - OFF - REMOTE  
 S2 Push button OPEN  
 S3 Push button STOP  
 S4 Push button CLOSE  
 V1 Indication light for End position - close  
 V2 Indication light for Common fault  
 V3 Indication light for End position - open  
 V4 Bluetooth  
 V5 Indication light for over torque operated - close  
 V6 Indication light for over torque operated - open  
 Display type: LCD type display for plain text display of Actuator information (Status & fault indication), Setting and calibration

**PS CARD** Power supply card includes Transformer and output Relays  
 PS-1 K1 to K6 Output Relays  
 F1 & F2 Primary fuses for power supply (mounted separately on mounting plate)  
 F3 Secondary fuse for control supply (mounted separately on mounting plate)  
 F4 Secondary fuse for space heater supply (mounted separately on mounting plate)

**SIL** SIL card for Safety I/O command / feedback  
**Adaptor** Adaptor card for connection between norm actuator switches & SIL card  
**K1 & K2** Reversing contactor for open & close operation

**Legend for Norm Actuator:-**

XA - Terminal connection at NORM actuator side (50 Pin plug in circular connector)  
 M - 3Ph motor  
 MWG B6 - Absolute encoder for limit (position) & over torque operation  
 S3 WSR - Limit switch, closing, clockwise rotation  
 S4 WOL - Limit switch, opening, counterclockwise rotation  
 S5 BL - Blinker transmitter  
 F1 TH - Thermo switches  
 R1 SH - Space heater in switch compartment

				<b>auma</b> <sup>®</sup>	Wiring diagram	
		DRAWN	RKP		27.04.2020	3WD/Epac-43845
		CHECKED	KMC		27.04.2020	
		APPROVED	YMJ	27.04.2020		



# CERTIFICATE

This certifies, that the company

**Auma India Private Limited**  
**38A & 39B, 2<sup>nd</sup> Phase, Peenya Industrial Area**  
**Bengaluru-560058 – Karnataka, India**

Is authorized to provide the product mentioned below

Description of product:       **ELECTRIC ACTUATORS WITH EPAC CONTROLS IN SIL VERSION**  
  **SA3 - SA100**  
  **SAR3 - SAR100**

In accordance with:           **IEC 61508:2010 Parts 1, 2, 3, 4, 5, 6, 7**

Registration No 20 21041 01  
Test Report No PS-21041-20-L-01  
File reference 21041-01

TÜV NORD Italia S.r.l. (TÜV NORD Group)  
Via Turati, 70                   20023 Cerro Maggiore (MI)



[www.tuev-nord.it](http://www.tuev-nord.it)

Validity  
from 2020-12-11  
until 2023-12-11

Cerro Maggiore, 2020-12-11  
[prodotto@tuev-nord.it](mailto:prodotto@tuev-nord.it)

*Please also pay attention to the information stated overleaf*

## 6 Disposal and recycling

AUMA actuators have a long lifetime. However based on frequent usage and site conditions, one will have to replace them. As our actuators have a modular design structure, they may be easily disassembled, separated and sorted according to materials i.e.

- Electronic scrap
- Plastics
- Various metals
- Greases and Oils

The guidelines to be followed are:

- Please collect greases and oils during disassembly. As these substances are hazardous to the environment, please make sure not to release them into water.
- Ensure sound disposal or recycling process for each disassembled material.
- Ensure observation of the national regulations for waste disposal.

**Electronic scrap** Auma India restricted the use of minerals like Cadmium, Tungsten, Cyanide and Mercury and ensures minimal usage of Lead in electronics parts.





# AUMA INDIA PVT LTD

## Head Office & Works

Plot No.: 38A & 39B, II Phase,  
Peenya Industrial Area,  
Bengaluru - 560058.

## Contact

Phone: 080-30412222  
Fax: 080-28392809  
E-mail: [info@auma.co.in](mailto:info@auma.co.in)

## Branch Offices:

### Noida:

#1310, Tower A, Corenthum  
Complex, Sector 62,  
Noida - 201 301.  
Ph: 0120-4272851-54  
E-mail: [VeereshS@auma.co.in](mailto:VeereshS@auma.co.in)

### Pune:

#405, Supreme Headquarters,  
Premises Co-Op Society Ltd.,  
Sr No: 36/2 Baner, Pune - 411045.  
Ph: +91 9763728621  
E-mail: [Nilesh.Patil@auma.co.in](mailto:Nilesh.Patil@auma.co.in)

### Chennai:

Flat No-4, Eden Villa, 1st Floor,  
10/21, West main Road,  
Shenoy Nagar, Chennai - 600030.  
Ph: 044-45524447  
E-mail: [Venkata.Ramanan@auma.co.in](mailto:Venkata.Ramanan@auma.co.in)

### Coimbatore:

Naveen Illam, 1st Floor, 3B  
Srinagar, B.R. Puram, Peelamedu  
Coimbatore - 641004.  
Ph: +91 9629641079  
E-mail: [Sakthi.Kumar@auma.co.in](mailto:Sakthi.Kumar@auma.co.in)

## Residential Reps.:

KOLKATA: +91 99374 31333  
HYDERABAD: +91 93426 94012  
AHMEDABAD: +91 9662660886

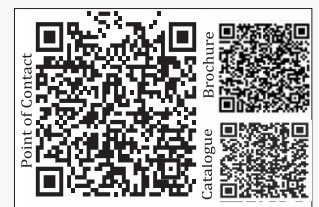

Access AUMA India Website



Follow us on LinkedIn



We reserve the right to alter the data according to the changes made. The product features and technical data provided do not express or imply any warranty.